

Preface

In your hands, you now have the report concerning our final project “Design of a fault-finding device”. This project was executed in the period February 2006 till June 2006 at the KHLim within the degree of Bachelor. The device we designed is actually an update of another final project from 15 years ago called “Foutsimulator voor relaischakelingen”. That project was realized by Jerry Claesen and Peter Knuts, their promoter was mister R. Peeters. The report of their project you can still find in the mediatheque of the KHLim under the reference E91/G/EM/05.

We would like to thank everyone who helped us during this project. Especially mister Theo Boesmans for giving us the opportunity to do this project at the KHLim. Also our promoters Wim Claes and Marleen Daenen for guiding us in the right way and all the other lecturers for their good advice and support.

Off course we'd also like to thank our parents for giving us the opportunity to accomplish higher studies.

Koen Broekx

Xavier Fontanet Molinero

June 2006

Contents

Introduction	
1	Analysis of the existing fault-finding device 5
2	Design of the new fault-finding device 8
2.1	The components 9
2.1.1	The PLC 9
2.1.1.1	<i>The CPU</i> 9
2.1.1.2	<i>In- and output cards for CPU n° 2</i> 10
2.1.1.3	<i>In- and output cards for CPU n° 3</i> 10
2.1.1.4	<i>CP communication card for CPU nr° 2</i> 10
2.1.1.5	<i>Front connector</i> 11
2.1.1.6	<i>DIN rail</i> 11
2.1.1.7	<i>Price comparison</i> 11
2.1.2	The Touch Panel 12
2.1.3	The emergency stop 12
2.1.4	The Magnetic safety switch 13
2.1.5	The Safety relays 14
2.1.6	The contactors 15
2.1.7	The thermal overload relays 15
2.1.8	The circuit breakers 16
2.1.9	The power switch 16
2.1.10	The pushbuttons 16
2.1.11	The supply 17
2.1.12	The connectors 18
2.1.13	The wire holders 18
2.1.14	The DIN rail 18
2.1.15	The enclosure 18
2.1.16	The auxiliary relays 20
2.1.17	The trespa plates 20
2.2	The Drawings 21
3	Construction of the fault-finding device 33
3.1.1	Building of the enclosure 33
3.1.2	Wiring of the components 37
3.1.3	Symbol labels 39
4	Programming the fault-finding device 41
4.1	The PLC program 41
4.2	The Touch panel program 43
5	Testing and simulating 46
5.1	Test of the device 46
5.2	Simulation of the fault-finding device 47
6	Cost - price calculation 49
6.1	Components of Breva n.v. 49
6.2	Components of Siemens NV 50
6.3	Components of Stäubli Benelux NV, Division Multi - Contact 50
6.4	Components of B.A.G. - Plastics nv 50
6.5	The Total Price 50
7	Conclusion 51

Bibliography.....	52
Appendix 1: Circuits and errors of the existing fault - finding device.....	53
Appendix 2: Selection of the components	54
Appendix 3: The price offers	59
Appendix 4: Drawings of the new fault - finding device.....	60
Appendix 5: Pictures of the new Fault finding device	61
Appendix 6: The PLC Program.....	63

Introduction

Our final degree project took place in the school KHLim in Diepenbeek, instead of in a factory. Although we made the project in KHLim, there were any problems concerning places and tools to do things in the right way, because the school is already prepared to do electrical and mechanical projects.

Our mission was to design a total new fault-finding device for relay motor circuits, which had to replace the current one because of security reasons. This device is being used in the electricity lab. It simulates errors in the relay motor circuits. The students then have to find these errors, there fore the name, fault-finding device a.k.a. error-simulator.

In the beginning of the project we were working in the electricity lab, checking the old simulator. The analysis of this simulator you can find in the first chapter of our report. In the 2nd chapter you'll be able to read something about the design of the new simulator. In the first part you'll find all the components we selected to build the device. The second part exists of an explanation of how the drawings were designed. They were all drawn in AutoCAD. We had to design at least 5 new stencils. In chapter 3 we talk about the mechanical and electrical construction of the device. We wired its components by using the electrical diagrams of the existing device. That wasn't easy because they were incomplete and normally we planned first to draw the electrical design of the simulator in Eplan. This last thing wasn't executed because we didn't have the time to do it anymore and we had to start building the simulator urgently or we wouldn't be able to finish.

After the constructing was finished we had to program the PLC and the Touch Panel. How that was done you can find in chapter 4.

After the simulator was finished we had to test if everything was working fine and then we could simulate all the programmed circuits. This part of the report is explained in chapter 5. In chapter 6 you'll find a price calculation and in the final chapter we wrote the conclusion.

1 Analysis of the existing fault-finding device

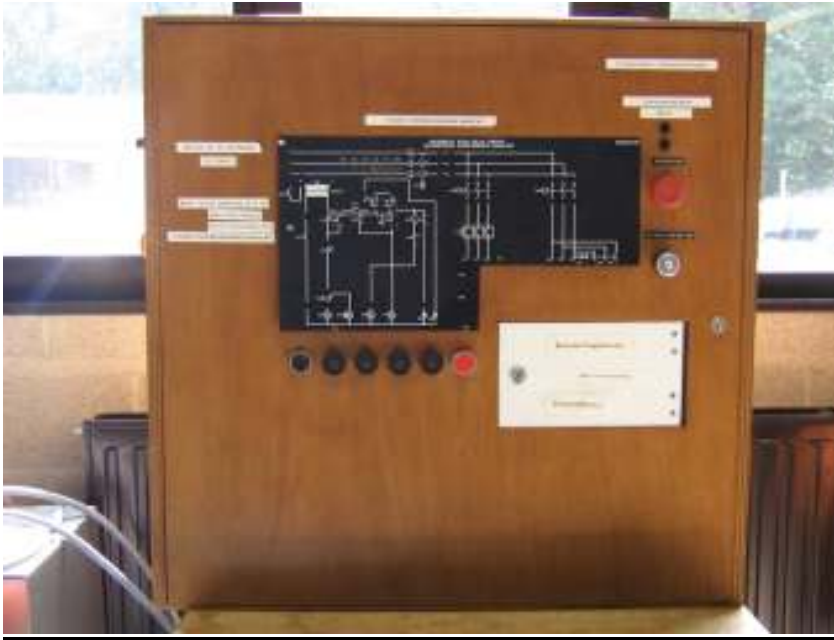

First we had to check how this one worked. We did this by doing all of the tests. There were 13 circuits and 13 possible errors. You can find these in Appendix 1, page 53. We always checked the common working of a circuit and afterwards we simulated all of the errors on it. As example I will show you how we did it with circuit B, error 3.

Circuit B: Direct On/Off Switching

We see that the power is on but the emergency stop has to be pushed. Then we put the mask of circuit B on the enclosure and connect the motor. Now we can pull out the emergency stop again. We choose circuit B with the switchbox and put every error off. After we put switch K6A on, which is the main relay, we can start the test.

Common working:

By pushing the pushbutton S1B, K1M will be excited. Because of this the overtaking contact K1M closes and we can release S1B. In the power circuit we see that the motor gets voltage and starts running. By using S0Q the engine will stop. This is what we checked and everything was working fine.

Working with error 3 integrated:

We switch off K6A, select error 3 and put K6A back on again.

The effect of this error is that we can't start the motor by pushing S1B. If we start measuring to search the error we measure 24V at A1 of the relay coil while pushing the start button. When we release the start button this voltage disappears again. Our conclusion is that the coil of the relay is defect.

Like this we checked every circuit with all its available errors. During the tests we noticed that some errors weren't working right.

- *Error number 5*: It's useless to simulate this error with the circuits E, J, N and P because with these circuits the signal lights never work, even when there's no error integrated.

- *With circuit B*: To simulate error number 6 we also had to switch on error 4 otherwise the error doesn't work.

- *With circuit E*: With this one we also have to switch on error 4 together with 6 if we want to simulate error number 6. There's also a difference in the effect of the error but it's normal. We have 2 motors here and only motor 1 will start to make a weird noise when error 6 is integrated. Motor 2 should also start turning after a few seconds but it doesn't because of the constant on/off switching of K1M.

- *With circuit F*: Here we also have to switch on 6 and 4 together to simulate error number 6. The effect is also the same but if we press S2B, the voltage disappears (because of a short-circuit).

- *With circuit H*: Error number 7 works different than it should. Here we can't stop the motor by pushing S1Q.

- *With circuit M*: If we simulate error number 8 the motor doesn't start turning in a different direction like it should but it does make a weird noise after he switches to delta. After a while the motor also falls out, this is because of the change of line wires. Because of that the motor only runs on 2 lines so the current is much bigger and it will overheat (PTC). We don't think this error is working wrong but it just works different because of the star/delta motor.

- *Error number 9*: This error causes a short-circuit with circuits F, G and H.

After this we checked the wiring of the simulator. We did this by following all of them and comparing this with the design drawings. Some things were connected different so we adapted this.

Now we read out the S5 PLC program. We analyzed this program and checked the wiring of the inputs and outputs of the PLC.

We also looked at what happened inside of the simulator with the different errors (which relays were switching etc.) and we compared this with the PLC program.

After working for such a long time with the simulator we noticed that it didn't always work like it should and in the end it totally didn't respond anymore if we pushed the start buttons used to start the motors. We checked the wiring and discovered that some of the cables (5) had bad contact so we fixed these and everything worked fine again.

So that fault – finding device had to be replaced for more reasons than just the security. Those reasons are the following.

- It's a very old device, more or less 15 years old.
- The most important thing to work with the device, its measuring points, are starting to get loose. This means the students aren't able to measure properly anymore because sometimes those measuring points are totally pushed out of their holes.
- The connections of the measuring points with the PLC and other components aren't very professional either. The wires are just soldered to the measuring points so because of the bad fixing of the measuring points in their holes, sometimes when they get pushed backward by measuring, the soldered connection breaks. We also noticed that sometimes the wires which pass toward the door had bad connection. They get cut by opening and closing the door.
- Another important reason why this device had to be replaced is the safety. Its safety is very poor. For example the measuring points, the students can just touch them with their hands and it aren't safety sockets. While on some measuring points there is a voltage of 400V when the power of the device is on. You can also just open the simulator when the power is on. This is very dangerous because on the inside is also a high voltage present, again on the measuring points but also at the supply which isn't covered by any kind of housing.
- Then we still have the black stencils for all the different circuits. The way that they have to be mounted on the door for measuring is not so good, sometimes they just fall off the door or they get pulled from the door during the measuring. The material of which they are made (plastic) isn't strong enough so some of them are folded, by falling on the floor or lying in the sun.

2 Design of the new fault-finding device

We had worked with the simulator for about 2 weeks so now it was about time we started with the design of a new one.

The first thing we did was to think about some extra measuring points we were about to place. In the end we came up with only 2 extra measuring points:

- One at clamp 14 of the overtaking contact K1M to be able to measure over this one and be certain that it is this one which is interrupted (with error 4). The same point we will need with error 6 to be able to measure that K1M is NC instead of NO.
- One at clamp 1 of the break contact of time relay K3A because we want to be certain whether it is the time relay which is out of order or the break contact.

Second, we made a list of all the components we would need to build our enclosure and we started searching for them. We started searching on the internet for a couple of days but since we didn't get much result out of this we contacted a lecturer and he gave us some catalogs. In these we found almost everything we needed but it was very hard to select the right things because we never did something like this. We also made a planning for the next couple of weeks and in the meanwhile we started drawing the circuits in AutoCAD. We had to adapt the drawings a lot.

When we finally found all of the components we made a list of it to ask for the price. We sent e-mails and faxes to lots of different suppliers and also phoned them. You can find the different price offers in the appendix 3, page 59. After checking all the price-offers with our promoters (we checked if everything was there and which supplier had the cheapest prices) we ordered the components.

2.1 The components

2.1.1 The PLC

In the existing fault simulator they use 36 inputs and 34 outputs of the PLC. The inputs consist of the switches which you use to select the circuits and the errors, the safety part of the control circuit and the pushbuttons. The outputs are connected to the relays, the measuring points and the LED's. Because we will use a touch panel for the circuit-choice and the error-choice we will only need 13 inputs. For the outputs we would now need 2 outputs less because we only use 2 LED's instead of 4. But we will foresee 2 extra measuring points to be able to measure some errors even better. Plus we will have to connect some extra relays to the PLC because we are going to simulate every error with the PLC unlike with the other simulator. There you had 4 errors which weren't simulated by the PLC but by the hardware of the simulator. Those 4 errors are related to 5 relays and then we still have the main relay which also has to be connected to the PLC. So that means we need 6 more outputs. Now, if we count a little bit, we see that we will need 40 outputs in our simulator.

2.1.1.1 The CPU

To select this one we considered the following 3:

- CPU 312C (6ES7 312-5BD01-0AB0)

compact CPU, 16kB RAM, 24V DC supply voltage, 10 DI/6 DO integrated, integrated functions, MPI; including slot number labels and 2 keys; MMC(max. 4MB) is necessary 128 counters, inputs and outputs: 256(this will do, with the first 313CPU you already got 992 in- and outputs and this way it incurs)

Dimensions: 80x125x130(width x height x depth) weight, approx. 409g

This CPU already has integrated DI and DO but because these won't be enough we think a CPU without an IFM will be better. Like the next one.

- CPU 312 (6ES7 312-1AD10-0AB0)

16kB RAM, 24V DC supply voltage, MPI; MMC (max. 4MB) is necessary 128 counters, max. inputs and outputs: 256

Dimensions: 40x125x130 weight, approx. 270g

This one aint programmable in SCL, GRAFH en HiGRAFH but we think we won't need this anyway.

- CPU 313C-2DP (6ES7 313-6CE01-0AB0)

compact CPU, 32kB RAM, 24V DC supply voltage, 16 DI/16 DO integrated, integrated functions, MPI, PROFIBUS DP master(8connections)/slave interface; MMC(max. 8MB) is necessary

256 counters, inputs and outputs: 8192

Dimensions: 120x125x130 weight, approx. 566g

We thought about this one because they've told us they might extend the simulator with profibus in the future so it was interesting to compare its price with the previous CPU.

2.1.1.2 In- and output cards for CPU n° 2

- SM 321 digital input modules (incl. labeling strips, bus connectors)

16 inputs, 24V DC → 6ES7 321-1BH02-0AA0

Dimensions: 40x125x120 weight, approx. 200g

-SM 322 digital output modules (incl. labeling strips, bus connectors)

16 outputs, 24V DC, 0.5 A → 6ES7 322-1BH01-0AA0

Dimensions: 40x125x120 weight, approx. 190g

We would need at least 2 of these, we could also pick a card with 32 outputs but that one is more difficult to connect and we got room enough in our enclosure.

So now we would need 8 more outputs so we could take another card of just 8 outputs.

8 outputs, 24V DC, 0.5 A, diagnostics capability → 6ES7 322-8BF00-0AB0

Dimensions: 40x125x120 weight, approx. 210g

2.1.1.3 In- and output cards for CPU n° 3

Here we wouldn't need an input card because the CPU already has enough integrated inputs (16). As output cards we could take the same as with CPU nr. 2 but just 1 card of 16 outputs because the CPU also has 16 integrated outputs. We also need another card of 8 outputs.

2.1.1.4 CP communication card for CPU nr° 2

In the future this one can be used to make communication via PROFIBUS DP possible.

→ CP 342-5 (6GK7 342-5DA02-0XE0)

- PROFIBUS DP master or slave with electrical interface for connecting the SIMATIC S7-300 and the SIMATIC C7 to PROFIBUS at up to 12Mbit/s (including 45.45 kbit/s)

- Communication services:

- PROFIBUS DP-V0
- PG/OP communication
- S7 communication (client, server, multiplexing)
- S5-compatible communication (SEND/RECEIVE)

- Easy configuration and programming over PROFIBUS

- Cross-network programming device communication through S7 routing

- Modules can be replaced without the need for a PG

2.1.1.5 Front connector

If we take CPU312 we would need 4 front connectors, otherwise, if we take CPU313 we would need only 2 front connectors:

20 pin, with screw-type terminals → 6ES7 392-1AJ00-0AA0

2.1.1.6 DIN rail

This one will be the same for both of the CPU's.

CPU nr. 2: $40(\text{width CPU}) + 40(\text{width input card}) + 120(3 \times \text{width output card}) = 200\text{mm}$

CPU nr.3: $120(\text{width CPU}) + 80(2 \times \text{width output card}) = 200\text{mm}$

→ The first rail which satisfies is one of 482mm (6ES7 390-1AE80-0AA0)

2.1.1.7 Price comparison

After we got the prices from Siemens we compared the possible combinations.

	Combination 1	Price	Combination 2	Price	Combination 3	Price
CPU	312C	296,00	312	228,80	313C-2DP	778,40
DI	SM321	114,40	SM321	114,40	////////////////////////////////////	////////////////////////////////////
DO	SM322x3	477,60	SM322x3	477,60	SM322x2	318,40
CP	CP 342-5	552,00	CP 342-5	552,00	////////////////////////////////////	////////////////////////////////////
Front Connector	20-pinx4	66,24	20-pinx4	66,24	20-pinx2	33,12
DIN-Rail	480mm	20,96	480mm	20,96	480mm	20,96
		1.527,20		1.460,00		1.150,88

Combination 3 would be the cheapest but since it wasn't sure profibus is going to be integrated in the future we chose for combination 2, only without the CP.

2.1.2 The Touch Panel

We asked the price of multiple control panels: operator panels and touch panels as well. The panel we bought is the simatic touch panel TP177A with a 5,7" blue mode stn-display and a MPI/PROFIBUS-DP interface. We chose a TP because they wanted us to use the new techniques and also because it can visualize graphics. It's being used to select the circuits and errors.

2.1.3 The emergency stop

We selected the PIT es1.11 E-STOP pushbutton for panel mounting.



Features:

- Conforms to IEC/EN 60947/-5-1/-5
- Protection type: IP65 in accordance with IEC 529, IP69K for PIT es1.15
- Protection class: II
- Mounting hole: 22.3 mm
- Mechanical life: 50,000 operations
- Release: Turn to right or left (right only on the PIT es1.12)
- Connection to safety contact blocks PIT esb1.1, PIT esb1.2, PIT esb1.3
- Dimensions: Diagram under [Product features](#)
- Approvals (pending): UL listed, SA, TÜV



The safety contact block we used with this one is the PIT esb1.2. It has 2 N/C contacts.



Features:

- In accordance with EN 954-1: Category 2, 3 or 4
- Electrical data in accordance with IEC/EN 60947-5-1
- Utilization category: AC15: A300; DC13: Q300
- Rated operating voltage U_e : 250 VAC (3 A), 24 VDC (2 A)
- Connection: Screw connections 2 x 2.5 mm, finger-proof in accordance with VBG 4
- Operating travel: Approx. 6 mm
- Protection class: II
- Contact material: Hard silver Ag/Ni
- Mech. service life: 1,000,000 operations
- Electr. service life: 1,000,000 operations (at nominal load)
- Min. current: 1mA
- Min. voltage: 5V
- Positive separation: In accordance with IEC/EN 60947-5-1, Annex K
- Dimensions: Diagram under [Product features](#)
- Approvals (pending): BG, UL listed, SA, KEMA, GOST, CCC



2.1.4 The Magnetic safety switch

We also selected a non-contact magnetic safety switch, PSENmag 1.1P-20. This one is being used to detect whether the door of our enclosure is closed or open.



Features:

- Magnetic action principle
- Approved for safe applications up to Category 4 of EN 954-1

- Version also available with approval for use in potentially explosive atmospheres in accordance with the ATEX directive
- Switching distances S_{on} from 3 to 8 mm
- Suitable for series connection
- Square or round design
- Protection types IP65 and IP67
- With and without LED
- M8 connector, 4 pin
- Approved with all Pilz evaluation devices

2.1.5 The Safety relays

Now we also needed 2 safety relays to build the safety circuit. Because we just had to cover a limited number of safety functions, we selected compact safety relays. Those are more appropriate for our application according to Pilz. In appendix 2, page 54 you can see how we selected these relays. In the table you can see the relay we used.

Emergency Stop Relays, Safety Gate Monitors, Category 4, EN 954-1
PNOZ X2P

Emergency switches and safety gate control switches in accordance with VDE 0113 part 1, 11/98 and EN 60204-1, 12/97



Features

- Dual-channel operation which detects shorts across the input contacts
- Supply voltage: 24 V AC/DC, 48 ... 240 V AC/DC
- Supply voltage 48 ... 240 V AC/DC: Galvanic isolation from the input circuit
- Automatic or monitored manual reset can be selected
- Plug-in connection terminals

2.1.6 The contactors

To select the contactors which have to make the motors run, we searched in a catalog of Telemecanique. You can follow our selection in appendix 2, page 54. First we looked in the table of class AC-3 because this class is related to squirrel cage engines. The motors have a capacity of 0,3kW therefore we end up at the lowest class in the graph. This means we can choose between LC1, LP1 and LP4-K06. LC1 is not an option because this one is for usage with an AC control circuit. Between the two relays that remain we chose a relay from the LP4 range because it's compatible with the outputs of programmable PLC's. The reason that it's compatible is that it has an internal disturb-reel.

The next thing we did is look with the 400V and a current of 6A because the nominal motor current is 1A. We chose a relay with screw clamps and 1 NO auxiliary contact, the LP4 K0610BW3. BW3 because of the control circuit voltage of 24V. We needed 11 relays like this for the power circuit and 2 for the safety circuit. It are contactors with low consumption from the TeSys range, model K which can be used to control motors.



2.1.7 The thermal overload relays

Mechanical overloads and errors of the feeding nets are the most attentive causes of overloads of motors. They cause a considerable increase of by the motor taken current, causing the motor to overheat. The result is that the life span of the engine decreases and the motor is sometimes even destroyed. For this reason it is necessary that overload of the motor is detected. The safety function against overloads are insured by thermal overload relays.

The thermal overload relay we've selected is the LR2 K0306 from Telemecanique. For the selection you can check appendix 2, page 54 again. The amount of relays like this

we needed is 2 because there are maximum 2 motors running at the same time with the different circuits.



The fuses which can be combined with these relays are the 2A aM type or the 4A gl type.

2.1.8 The circuit breakers

These are from Legrand. For the line wires before the main relay we used the DX 6000A 10 000A Curve C which belongs to the magnetic-thermal automatic switches. It's made for three pole 400V~ circuits with a nominal motor current of 1A. We used just one like this.

Between the DC power supply and the PLC we also needed several circuit breakers to protect the CPU and the input module and output modules. Here we selected the DE 3000A Curve C, which also belongs to the magnetic-thermal automatic switches. Only this one is for a single phased 230/400V~ circuit with a nominal current of 2A.

We bought 8 of these automats, 1 to secure the CPU, 1 for the input card, 1 for each output card and in total there are 3 output cards. Then we needed 3 more for the control circuit. The selection of these circuit breakers is also located in appendix 2, page 54.

2.1.9 The power switch

Here we used the VBD-N12, also from Telemecanique. This is a 3 - pole charge breaker which can bear a thermal current of 12A.

2.1.10 The pushbuttons

These we needed to start and stop the motors. We've used 4 green pushbuttons (XB4-BA3311) and 2 red pushbuttons (XB4-BA4322).

2.1.11 The supply

We needed a DC supply to power the PLC and the control circuit. The supply we selected is one from the factory Erea.

DR-SPS120W24V

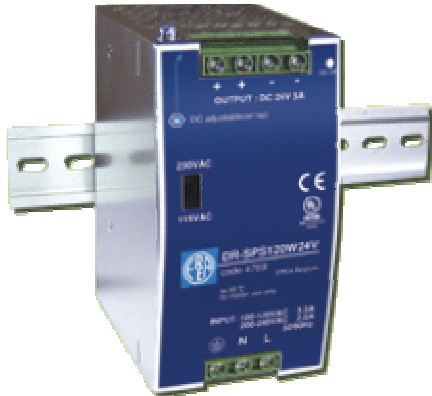

Type	DR-SPS120W24V	Code	4769
Weight	0,650 kg	package	1 P
EAN-code unit	5414503047694		

Ps	■ 120 W
Upri 50-60Hz	■ 88-132 Vac + 176-264 Vac 254-370 Vdc
U sec	■ 24 Vdc Tolerance +/- 1% Adjustable 24-28 Vdc
I sec	■ 5 A
Ambient temperature	■ 35 °C
Technical data	■ Overload protection 105-150 %

If all the outputs of the PLC had to work together, the PLC would use a current of 10A (2A per card). But because this is not the case and only a few outputs have to provide power at the same time a supply of 5A will be fine.

2.1.12 The connectors

The connectors we used for the measuring points on the door of the simulator are from the factory Multi-Contact. For the power circuit we used black connectors, for the control circuit blue ones, for the earth yellow-green ones and for the thermal contact of the motors green ones.

2.1.13 The wire holders

These are also from Legrand. We bought 3 Lina 25 wire holders with a width of 60mm, a height of 40mm and a length of 2m.

2.1.14 The DIN rail

To mount all of the components we used an Erico DIN rail of 35mm wide, 7,5mm high and 2 meters long.

2.1.15 The enclosure

To select the enclosure we had to take into account the size of the stencils. These were changing all the time but we thought the maximum width of our enclosure would be 1m so we selected a few of that size.

- AE1110.510
- AE111.510
- AE1213.510
- AE1213.100

On the website of Rittal we couldn't find anything about how many doors these enclosures had so we phoned them. Unfortunately all of these models had 2 doors.

They said 800mm was the maximum width for enclosures with 1 door and a average height. Enclosures of 2m high were also available with one door but that was too big. So we decided to buy an enclosure of 800mm wide since the size of the stencils had to be changed anyway or they would have been too heavy. We used an AE 1180/500 Rittal enclosure.



Item Specification Sheet

Model No.	AE 1180.500
Designation	Compact enclosure AE, painted RAL 7035, with mount. plate, single-door
Variant	with mounting plate, spray finished
Packs of	1

Width	800 mm	Mount.-Area	k.A.
Height	1.000 mm	Volume	280.80 dm ³
Depth	300 mm	Net weight/piece	53.90 kg

EAN	4028177252424
Duty No.	85381000
eCl@ss 5.0	27-18-01-02

Item Attributes	
Material	Sheet steel
Surface finish	<u>Enclosure and door</u> : dipcoat primed, powder-coated in textured RAL 7035 <u>Mounting plate</u> : zinc-plated Protection category IP 56 Complies with NEMA 4

Protection Cat.
IP 56

2.1.16 The auxiliary relays

Here we used 3 Releco relays.

General purpose. Change-over contacts, 10A

Terminals: tubular 8 pins

2 contacts

Max. AC Load 10A/250V AC1

Max. DC Load 0,5A/@110V DC1

Contact material AgNi



Additions to the coil:

LED (Not for latching)

Free wheeling diode (DC only)

Polarity and free wheeling diodes

Rectifying bridge do AC / DC relays

RC suppressor (only MR-C types)

2.1.17 The trespas plates

We needed trespas plates to make the stencils. The sizes of these stencils were defined by the drawings. Since these kept changing all the time we already searched for suppliers of trespas and when the sizes were almost definite we started to ask for prices.

2.2 The Drawings

The drawings of the circuits of the simulator are an important part of this project. It consisted of, redrawing five old circuits made on thin plastic masks, changing all the structure and redistributes the spaces.

The first time we spent some time to analyze and measure the sizes of the old circuits, to be sure how we could start to draw the circuits correctly.

One of the first instructions that we received from our promoters was about the sizes. All five circuits had to be drawn in identical sizes and all the common parts had to fit in the same place. For example, the S0Q NC contact, had to fit in the same place for all the circuits, because the measuring point of that contact had to be in the same place in the internal simulator.



Symbol S0Q from the circuits

Because the holes of all the measuring points had to be in the door of the simulator, we had to put correctly every hole in the same measured place for each circuit and in the door of the simulator as well.

When we were ready to start to draw, first we drew two big blocks, the block of the control circuit, and the block of the power circuit, it was one first little guide to know how big the drawings could be, and one first step to start structuring the circuits.

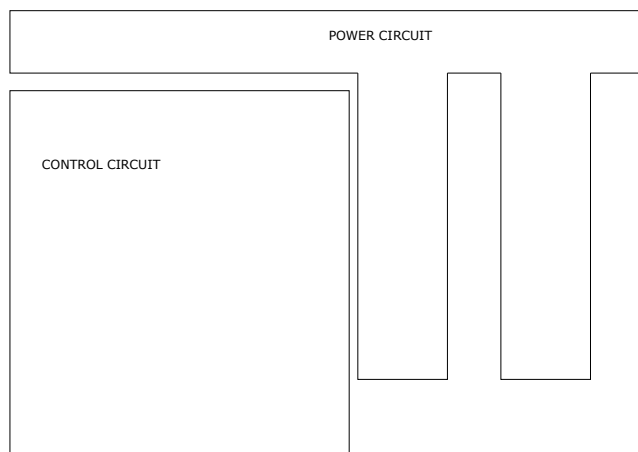

First distribution of the drawing of the circuits

After that we made the reference lines, the reference lines are the invisible lines which function is to make the shell of the circuits, and to know the exact distribution of all the real lines and symbols in each circuit.

We drew 20 vertical lines, 20 millimeters separate each from the next, and we drew 30 horizontal reference lines, as well, in another type of line and color.

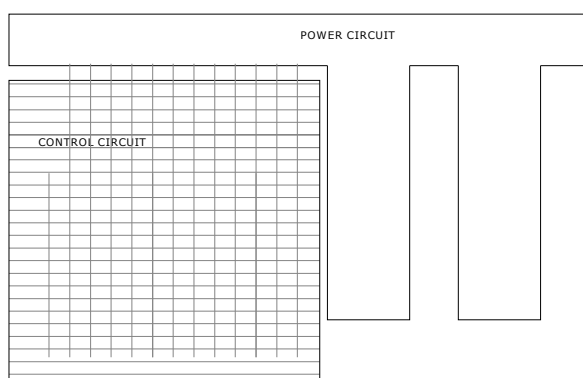

Placing the reference lines for start to draw.

In the moment that we had all the pattern lines, we started to make all the wblocks, the wblocks are all the symbols that appear in the circuits, like normally open/closed contacts, the relays, contact fuses, measuring points, etc.

That way of working was the most comfortable and the best way for draw.



Three of the wblocks that we made for the circuits

So when you have drawn all the symbols with wblock you are able to use it at every time and every circuit and there is the insurance that in all the circuits the same symbols are going to be identical.

In that case the easiest drawing symbols was the control circuit ones, and we got more difficulties with the trifasic circuit symbols, which had to be synchronized with the lines separation and we had to change these more than one time.

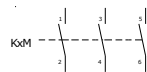

Trifasic wblock for the power circuit

Then we had all the guide lines and all the wblocks necessary for start to draw the circuits.

We started drawing the “Dahlander rotation circuit” because is the biggest and the most complete one; the first block that we fit in was the power circuit block, because was the easiest.

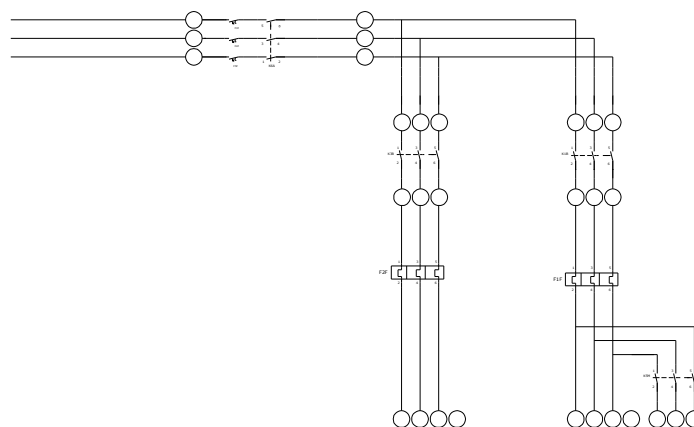

Dahlander power circuit from the first structure

The Dahlander is one of the circuits that have more components, so we decided start for this one, it worked like a base of the other circuits, so after that, for the other circuits, we had just, to modify Dahlander and we could get the others from the modified Dahlander.

After that we drew the control circuit, first we located all the symbols of the circuit, after that we put all the measuring points that we decided that we need.

Finally we just completed the circuit drawing the connection lines between the symbols and the measuring points.

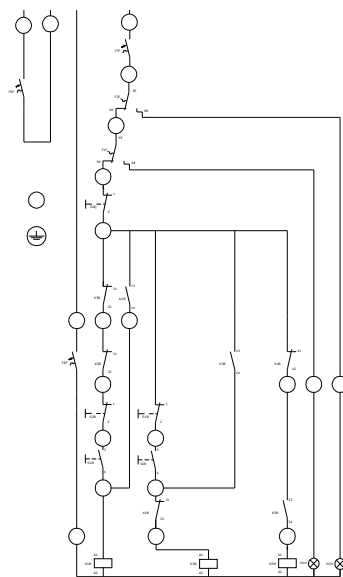

Dahlander control circuit from the first structure

When we already finished the first circuit “Dahlander rotation circuit”, and we tried to start the second drawing we realized that was impossible follow the instructions that had to be all circuits equal, because the control circuit of “Star-Delta circuit” have a branch with more contacts so had to be bigger than the first.

So in consequence we had to redraw again the Dahlander rotation, but now paying more attention to the other four circuit’s components and measuring points.

The most difficult part of the draws came, because was really more complicate draw one circuit and take care of the sizes of the other four circuits.

On the other hand, we realized that make the other circuits was really easier, because we just had to copy the power and the control circuits, and change in these all the differences between the copied one.

Therefore, we could get the five circuits, drawn by AutoCAD in more than one week, and after that we had to copy and paste all the five circuits in one new document, so, in a single draw which joined all of five circuits, of course they had to fit one from each other. The results were like one circuit, but in reality they were five circuits together already.

Then we had to print the “all circuits drawing” using for that more than eight A3 papers for one single draw, and we showed the puzzle to the promoter.

The sizes of the draws in that point were 850 mm wide and 700 mm high.

The second problem came when, checking the printed circuits with the promoters, we realized that, in the “all circuits drawing”, the holes of the measuring points were wrong distributed, since they had to be in orthogonal position, and, actually, all the holes were placed without any rule.

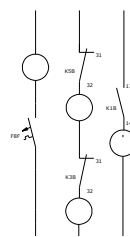

Wrong first distribution of the holes and contacts

So it means that we had to redraw all the circuits again, practically in all the branches of the control circuit, because it was full of holes.

Even the sizes of the circuits had to be different, and it could be a problem for the order of the trespas material, which had to wait more time than the other material.

Therefore we started to modify the style of drawing, we had to place new reference lines, so we create different horizontal levels, every line in different levels, and after that all the holes were placed in the nearest level until, in each circuits, all the holes were placed in all the reference lines.

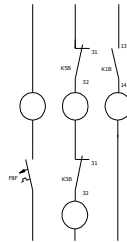

Right definitive distribution of the holes and contacts.

That, of course had to be done for all of five circuits, and all of five in the same place. So, finally, when we got the circuits with all the holes orthogonal placed; we had just to do the new “all circuits drawing”.

Next, we realized that, in consequence of all of these movements, the circuits had different sizes each from the others, so we had to modify again some parts of some circuits until get the common size for all.

Now we could print the “all circuits” draw in peaces of A3 paper, for second time, the trouble was when we built the printed document and analyzing it, we realized that it was bigger than the first one, since in consequence of all the changes the circuits became bigger.

The sizes in that point were 850 mm wide, the wide was not modifying, and almost 800 mm high; and these were too much big for the trespa plate sizes that we can accept.

In this way we showed the arranged circuits to the promoters and for them the placement of the holes, and all of the symbols was good, but, like we suspected, the general size of the draws was to much big.

We have to remember that these circuits have to be printed in trespaplate and it had to be placed in the door of one enclosure, so, the drawings couldn't be bigger than the door of the enclosure that we have to order.

Following these items, we arranged with the promoters that the solution could be making the symbols smaller and in consequence get the entire drawing smaller.

For to do it even smaller, we could get the branch lines of the control circuits closer ones from the others, and now the complete draw became thinner also.

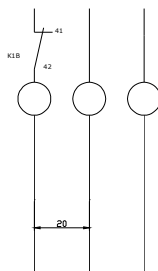

The separation between the lines was 20 mm

At the same time we had to change one type of symbols, the light sign symbols, since, in the beginning we drew it like one cross into one round in the circuits, and the real holes of the lights in other side, out of the circuits, but, at that time we decided to erase the symbols and put the holes of the lights directly on the circuit, in that way it could be more tidy.

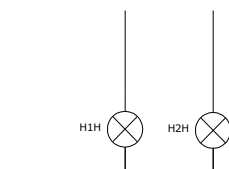

Sign lights (before)

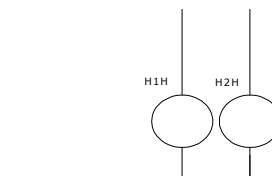

Sign lights (after)

Anyway, we had drawn the other symbols with the wblock option; it means that we had to remake all the symbols in the same way, redrawing all the wblocks and after that replaced it against the old ones.

The results were very good and at that time the sizes of the shablon were more acceptable, since, we reduced it almost 100 millimeters from the first draws.

Nevertheless, in this time we had to draw a supply in the control circuit, instead the transform block that we drew in the first time.

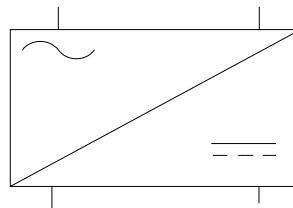

Supply

Meanwhile we had to draw also the door of the enclosure, there we were going to put on the circuits that we made, then we should draw all the extern components from the door, as well, were the six push buttons, the emergency stop button, the thermal contact measuring points, the power stop switch and the most important, the operational touch panel.

So, we had now another trouble, the size of the door was fixed which were 800 mm wide, and 1000 mm high, unchangeable because we already ordered it from RITTAL and they have standard sizes.

Therefore, we ought to do it carefully because the circuits and all of those components couldn't exceed at all these sizes, we had to take care that the power stop switch had not to be placed in the door of the enclosure, since it had to be placed at the right side of the enclosure

So, the distribution that we first decided was, place the shablon in the higher part on the door, and in the low part we could fit from right to left, the touch panel, the emergency stop button the thermal measuring points and the six push buttons; and all of that fit in the door sizes, so it was ready.

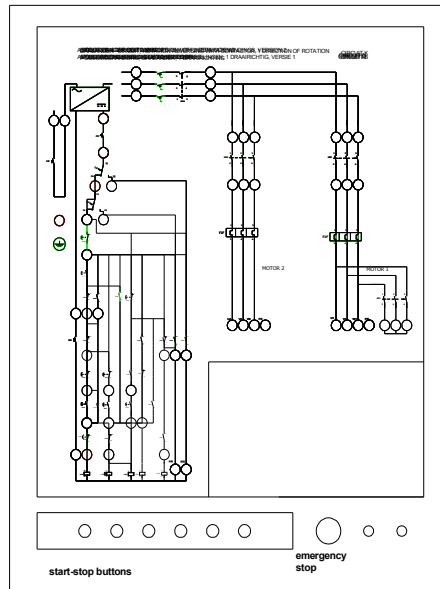

Old distribution of the circuits and external components in the door of the simulator

Therefore, for first time, we got the document “definitely complete drawing” archive printed, now with less A3 papers, and we showed it to the promoters

Now the sizes of the shablon with the circuits were 738 mm wide and 695 mm high, and all the complete draw, with the door, was 800 mm wide, and 1000 mm high, actually the size of the door.

But; in the following meeting with the promoters we were discussing with them for a long while and finally we came to the conclusion that the distribution of the “external components” was not the best option, since, the touch panel was fixed below of the measuring points, so, the time that we would connect the motors with the measuring points, the wires could block the touch panel, or even active this.

So, the conclusion was change all the distribution of the door, shablon, touch panel and buttons, and the distribution of the circuits, from the shablon, since, we needed to change the sizes of these.

Meanwhile, the promoters advise us that in the trespas the holes of the sign lights had to be much bigger than the holes of the door, the reason is that the “mushroom” of the sign lights had to fit inside the shablon, getting a flat board.

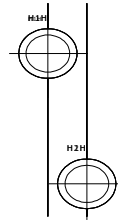

Double holes for the sign lights.

We needed a really shorter circuits than we had in this moment, so, the part of the circuits that we had to modify was to the power circuit, the objective of the modification was get the shablon shorter, to be able to fit the extern components in the top part of the door.

The problem came when we realized that because the control circuit was the shortest possible, since we already got it before, so the unique part he could get shorter was the power circuit, then we got a non squared trespa plate, in other words, we got the right part of the plate shorter than the left part.

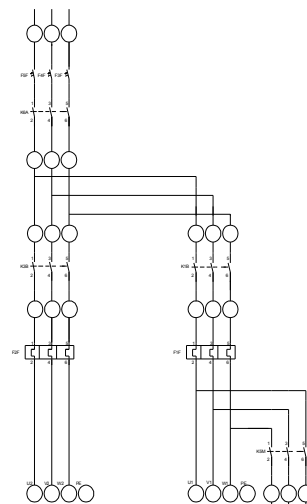

Dalhander power circuit, definitive structure.

But it was enough; because, like I already commented we decided to put the touch panel and the other components in the top part of the door, and, in the part of the shablon that we cut in the right part, the touch panel and the emergency stop fit in. The 6 push buttons were fixed above the emergency stop, and the thermal measuring points were all

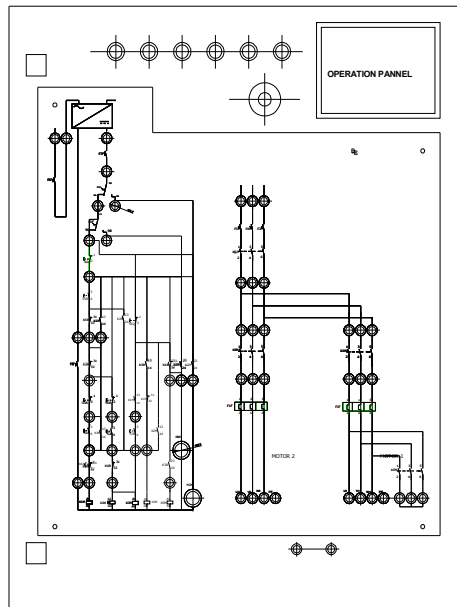

Definitive distribution of the circuits and external components on the door of the simulator.

Therefore in that time we got a totally different structure of the door of the enclosure with all the buttons and emergency stop on the top, with the touch panel in the corner, and the circuit below.

So, with the promoters we agreed that it could be the definitive structure of the circuits.

Some time after, specifically the moment that we were going to order the definitive piece of trespas material, we had to decide the place of the shablon on the door, so how it could hold there by itself.

And the decision was to make one hole in each corner of the shablon and hold it by four screws so in that time we got another little problem.

The space between the circuits and the edge of the shablon was too small in the lowest part of the piece, specifically if we have to make some hole there, and the solution we

found was make the shablon bigger, by AutoCAD, so it was just placing the low line of the shablon 15 millimeters below.

After that we were able to make the holes in the four corners of the boards, in the way there could be space enough for 7 millimeters of diameter.

Meanwhile we were checking the drawings to make the holes to hold the shablon, with the promoters we decided remove the titles of the circuits and put just the alphabetic letters from A to E instead, in the shablon.

At last we realized that the size of the numbers and the reference letters from all the symbols of the circuits were too small in the draws, because in trespa shablon they had to become engraved.

So at that time we had to make all the names of the symbols from all the five circuits bigger.

That was the last and definitive change in the long building of the circuits by AutoCAD program, by that time we got the circuits that in the future have to be engraved in a shablon of trespa material.

All the drawings of the five circuits from the PLC and the door of the enclosure are situated in appendix 4, page 60.

3 Construction of the fault-finding device

When the drawings were finished, and all the components arrived, we could start constructing the simulator. For the mechanical part we were allowed to work in the mechanical workshop and use the necessary tools. The tools that we needed for the electrical part we got from the electricity lab.

If you want to see how the enclosure looked like when it was finished, you can check appendix 5, page 61 for some pictures.

3.1.1 Building of the enclosure

First we thought about how we were going to place the components in the enclosure. We made a sketch in which we defined the position of the DIN-rails and the wire holders. After that we sawed them in the right length and drew reference lines for the placement on the mounting plate. On those lines we had some holes made to mount the rails and wire holders with a bolt/nut connection. Then we mounted the mounting plate back in the enclosure and mounted all of the components on the rails.

The second thing we were going to do was holing the door. For that, we first had a real size drawing of the door printed on an A0 paper. This drawing we were going to tape against the door but we had to make sure it was in the right position. To do that we drew a couple of reference lines on the door with a square to have everything under a 90° angle. Then we made some holes in the drawing and placed the drawing on the door making sure the reference lines and the drawing lines were at the same level. After that we taped the drawing against the door and marked the position of all the holes that had to be made with a center punch. The next thing we did was off course drilling all the holes. Here fore we placed the door on a pallet so we wouldn't damage the workbench on which it was laying. In total there are 67 holes consisting of 27 measuring points in the control circuit, 29 measuring points in the power circuit, 6 pushbuttons, 1 emergency stop, 2 light signs and a thermal contact. First we pre-drilled every hole with a 6,55mm and a 4,75mm HSS drill. Second, we drilled every hole with a drill of 9,2mm. And finally we drilled every hole once more with a 11,75mm drill. The holes of the pushbuttons, the E-stop and the light signs had to be respectively 22,

22,3 and 22,5mm big. Those 9 holes we finished with a staircase drill, more specifically the FORMAT 6-30Ø, HSS 6E7, ROTA STOP. We marked the 22mm and drilled up to this mark. We also made 4 small holes for the mounting of the stencils. They will be fixed on the door with a bolt/nut connection. Now we deleted all the wire-edges with every hole, on the outside but also on the inside of the door.

When this was finished we still had to make a big hole for the touch panel. We had to cut out a rectangle of 198mm wide and 142mm high. First we drilled a hole of 8mm in every corner of that rectangle, which we already marked on the door as well. This was necessary to be able to cut out the rectangle with a saw. That way we could start sawing in those holes. When we got the rectangle out the door we filed the wire-edges away. We mounted the touch panel after the electrical wiring and the plc program were finished. We used the provided plastic clamps to do this. These mounting clamps hook into the recesses on the HMI device.

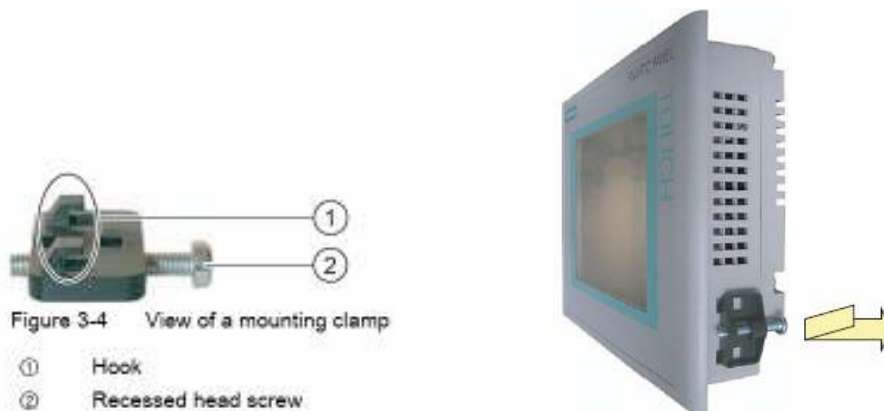

Now we were ready to mount all the connectors(safety sockets), push-buttons and the E-stop on the door.

The safety sockets we just had to insert into the door and afterwards mount the lock washer and screw on the ring nut by hand. After that we tightened the ring nut with a self-made tube spanner from the lab and counter(inside the socket are indents) with counter spanner SS2. So far for the safety sockets.

In the figure below you can see how we mounted the pushbuttons and the signal lights.

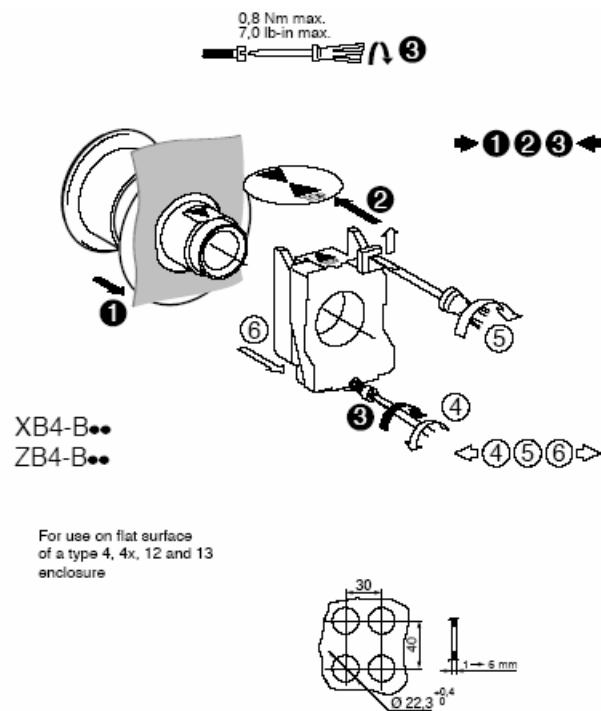

To mount the emergency stop, we just had to insert its actuator into the opening in the door as shown in the following figure. Then we used the plastic nut to secure it (26mm spanner). After that we pushed the contact block onto the actuator and turned it clockwise to engage.

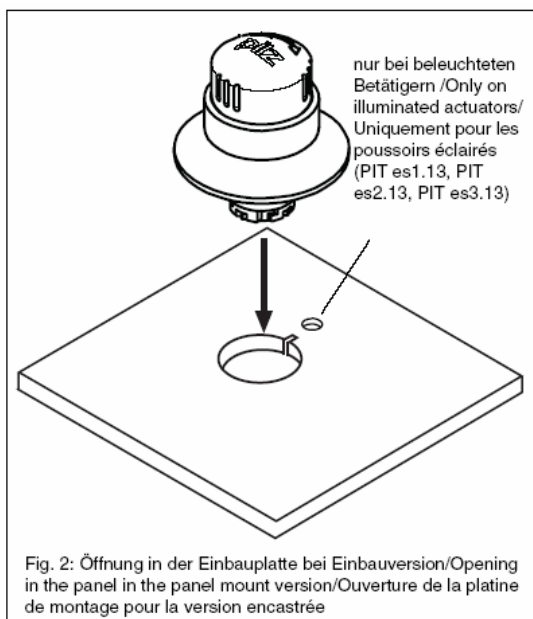

To mount the safety switch we designed an L-profile on which we screwed the switch with 2 M4 screws. We fixed the L-profile inside the enclosure with TEC 7, some sort of silicone. We used that to save some time and because there aren't any strong forces being exercised upon the profile anyway.

The magnet included with the safety switch we fixed against the door. This we also did with some screws and bushes to position the magnet in the right place beside the switch. We assured the operating distance between both was within the given values(0,5 and 6mm).

On the side of the enclosure we drilled 2 holes of 22mm, 1 for the power switch and the other for the swivel. The one for the power switch, we drilled at a height of 700mm and 200mm from the back of the enclosure. First off course, we marked both holes with a center punch.

The hole for the swivel we drilled at a height of 50mm and 50mm from the back of the enclosure. For the power switch hole we successively used a 6mm HSS drill, a 11mm HSS drill and the staircase drill mentioned above. After that we filed out a small groove. For the other hole we also used that staircase drill, but first a drill of 4,5mm, then a 8mm HSS drill and a 12mm HSS drill.

When the holes were made we filed the wire edges away and mounted both of the components.

Since every component that had to be mounted on the door was there, we could start dividing some wire holders on the door. We used a square to draw the lines for the position of those wire holders so they were in a 90° angle. Here we also used the TEC 7 to fix them on the door.

3.1.2 Wiring of the components

We started to do the wiring work when the enclosure was already built and all the components were fixed. We needed two types of wires: the black wires, for the power circuit, they were wide wires, especially to bear several increases of power.

Also the blue wires, for the control circuit, that type of wire was thinner, because the control circuits use less current than the power circuit.

And moreover, we had to follow that, according to current rules, the black color is always for the trifasic circuits, the blue color is for 24 volts DC and the red color is for 24 volts AC.

So, we already started wiring the power circuit connections, more specifically the safety circuit, it means, we wired from the trifasic safety contact to the supply, and from the supply to the different relays contacts that we had to use for the power circuit, the eight circuit breakers were wired to the 24 volts + from the supply.

In the time that we had the first safety connections ready we started connecting all the contact relays.

For the power circuit we had to connect each of the three phases (L1, L2 and L3) from the negative of K6A to the positive of K1M, and after that making bridges of L1+ (K1M) to L1+ (K2M), L2+ (K1M) to L2+ (K2M) and L3+ (K1M) to L3+ (K2M) and consecutive for K3M and K4M.

Those connections were in the common connection to get the 24 volts of power from the trifasic contactor to K6A L1+, L2+ and L3+.

After getting the power for all of the contact relays we went on to the next step, the circuits wiring.

So we took the physical draw of the connections of the power circuit and we went on connecting all the relays (K1M, K2M, K3M K4M, K5M, K6A, K108, K112, K113, K114, K116, K1, K2 and K3) and the thermal contacts (M1M and M2M) connecting them between, to get the connections of the printed of the physical power connections circuit.

That was not a very difficult thinking work about connections, but the difficulties had been in the time that we had to connect two or three black wires in a same connector of some relay, because the holes were too small and there had not enough space so it went a little bit hard to do it.

With the power circuit already connected we started with the control circuit connections, the control circuit were supplied for 24 volts DC, instead of the trifassic supply of the power circuit.

Those connections were less evident than the power circuit connections, so, we had to spend more time analyzing the physical connection circuits of the old simulator, and the internal circuits from the PLC as well.

So when we were able to understand the control circuit wiring, we started for the safety connection as well and after that we were connecting all of the relays (A1) to the outputs of the PLC.

More outputs were coming from A6, A7 and A8 from the circuit breakers.

We wired as well from the M1M and M2M thermal contacts to the help contacts K1, K2 and K101. With all of those connections we already made the wiring of the control circuit.

Meanwhile we were wiring, we were making the holes of the door of the enclosure, for the measuring points, so in the time that we already finished the wiring of the components of the plate, we were ready to make the connections of all the measuring points.

The trifasic connections to the power circuit measuring points were made with the black wires, and taking care of the physical connection for the power circuit, the same that we checked for the components connections.

We started to connect all the power circuit measuring points with the corresponding relays from the plate panel.

3.1.3 Symbol labels

The wiring of the simulator has been done in a way that it'll be perfectly understandable and clear to do checks and make changes.

We've put labels in both ends of each wire in a way that, in one side, the label describes the place where the other side is connected.

Next we are going to show the list of the labels that we used in the wiring, with the meaning of each one as well.

- E0.0/1/2/3/4/5/6/7: Block 0 of the Input card of the PLC; connection 0 until 7
 - E1.0/1/2/3/4/5/6/7: Block 1 of the Input card of the PLC; connection 0 until 7
 - U3 0.0/1/2/3/4/5/6/7: Block 0, Output card 3 of the PLC; connection 0 until 7
 - U3 1.0/1/2/3/4/5/6/7: Block 1, Output card 3 of the PLC; connection 0 until 7
 - U4 2.0/1/2/3/4/5/6/7: Block 2, Output card 4 of the PLC; connection 0 until 7
 - U4 3.0/1/2/3/4/5/6/7: Block 3, Output card 4 of the PLC; connection 0 until 7
- (E = Eingang, U = uitgang)
- PST1/2/3: Power Switch, connection 1, 2 and 3.
 - MAL1/2/3: Main Automat, connection Line wire 1, 2 and 3.
 - 24V: +24 volts DC from the Supply
 - 24VM: -24 volts DC from the Supply (M = mass)
 - L: 230 volts AC from the Supply
 - A1/2/3/4/5/6/7/8: Circuit breakers, from the 1 until the 8 (A = automat)
 - SCA1/A2/13/14/23/24/S33/S34/S11/S12/S21/S22/Y36/Y37: All the connections of the safety relays. (SC = Safety Contactor)
 - C11: Auxiliary relay K1; connection 1 (11)
 - C12: Auxiliary relay K1; connection 2 (A1)
 - C13: Auxiliary relay K1; connection 3 (14)
 - C17: Auxiliary relay K1; connection 7 (A2)
 - C21: Auxiliary relay K2; connection 1 (11)
 - C22: Auxiliary relay K2; connection 2 (A1)
 - C23: Auxiliary relay K2; connection 3 (14)
 - C1011: Auxiliary relay K101; connection 1 (11)
 - C1012: Auxiliary relay K101; connection 2 (A1)

- C1013: Auxiliary relay K101; connection 3 (14)
 - C31/2/3/4/5/6: Auxiliary safety relay K3, connection 1 until 6
 - C41/2/3/4/5/6: Auxiliary safety relay K4; connection 1 until 6
 - C6A1/2/3/4/5/6: Relay K6A; connection 1 until 6
 - C1M1/2/3/4/5/6: Relay K1M; connection 1 until 6
 - C2M1/2/3/4/5/6: Relay K2M; connection 1 until 6
 - C3M1/2/3/4/5/6: Relay K3M; connection 1 until 6
 - C4M1/2/3/4/5/6: Relay K4M; connection 1 until 6
 - C5M1/2/3/4/5/6: Relay K5M, connection 1 until 6
 - C1081/2/3/4/5/6: Relay K108; connection 1 until 6
 - C1121/2/3/4/5/6: Relay K112; connection 1 until 6
 - C1131/2/3/4/5/6: Relay K113; connection 1 until 6
 - C1141/2/3/4/5/6: Relay K114; connection 1 until 6
 - C1161/2/3/4/5/6: Relay K116; connection 1 until 6
- (C = Contactor)
- M1M95/96/97/98: Thermal overload relay F1F; connection 95 until 98
 - M2M95/96/97/98: Thermal overload relay F2F; connection 95 until 98
 - STOP01/2: Push button S0Q, connection 1 and 2
 - STOP11/2: Push button S1Q, connection 1 and 2
 - S1B2: Push button S1B NC
 - S1B4: Push button S1B NO
 - S2B2: Push button S2B NC
 - S2B4: Push button S2B NO
 - S3B2: Push button S3B NC
 - S3B4: Push button S3B NO
 - PPB: Reset push button connection 1
 - SPB: Reset push button connection 2
 - ES: Emergency stop
 - L1L: Sign light H1H
 - L2L: Sign light H2H
 - TPL: Touch Panel Line (24V)
 - TPM: Touch Panel Mass
 - MP...*...: Measuring Points.
- *From MP1 until MP54

4 Programming the fault-finding device

All the programming happened in the lab of automation because only there we could work with the official version of the S7 program.

To program the PLC we decided to start from scratch and not to analyze the whole S5 program of the old simulator because it wasn't easy to understand. That's because everything was located in OB1 so there wasn't any kind of structure in the program.

It probably would have taken much more time as well and our program would be different anyway because we just had to program 5 circuits instead of 13. This means we only used 32 outputs instead of 40 because there are 8 measuring points in the remaining circuits which aren't used in the 5 circuits we programmed.

The touch panel program was made with the WinCC program from the PC.

4.1 The PLC program

We started with writing down a list with all the inputs and outputs of the PLC and giving them a name (symbol list). After that we defined what had to happen in the program, involving the inputs and outputs. Using this information we started to program the PLC. We used different materials like FC's instead of putting everything in OB1.

While programming the circuits, we noticed that it took a long time before we had defined the conditions of just one measuring point. Therefore we printed the circuits on an A3 paper so we were able to analyze them again and think about how they would look like with the errors included. So in each circuit we introduced the errors it had by using contacts and relays. When that was done, we just had to translate all the relay motor circuits to ladder diagrams.

In the following table you can see which errors are available for each circuit.

		E R R O R												
C		1	2	3	4	5	6	7	8	9	10	11	12	13
I	A	X	X	X					X				X	X
R	B	X	X	X	X	X	X						X	
C	C	X	X			X		X	X	X			X	X
U	D	X	X			X			X				X	X
I	E	X				X			X	X	X	X	X	X
T														

The structure that we followed to make the program as easy as possible was in 9 different blocks. The safety program, the circuit selection program, the 5 circuits, the relay outputs and after that the measuring point outputs.

The first and most difficult program that we made was the safety program. We had to rely on all of the safety components (emergency stop, magnetic switch, thermal contacts) and also the start and stop button, in a good distribution to make it work. We used the FC1 block for that.

The circuit selection program was the easiest part. We just had to relate the touch panel markers from each circuit, to each circuit from the PLC program. That was in the FC2 block.

After that we started to translate the working of the 5 circuits to a LAD program. We did this by following the lines of the control circuit, leading to each measuring point connected to the PLC outputs. In that way we defined the conditions that had to be accomplished, in order for the measuring point to have power. Each circuit is programmed in a different FC, going from FC3 until FC7.

In the next FC we defined the conditions for powering the relays and the sign lights. This we did by using the measuring point's right above them. If they had power, the relay and sign light outputs were allowed to be powered as well. We put all of that in one FC because for each circuit it are the same relays which are being used. We just made the difference by also putting the selected circuit in the conditions. We used the FC8 block for this part of the program.

The last block was an extra one. Because we decided to use markers for the measuring points in the program, we had to relate each marker to the corresponding output of the measuring point.

The Siemens S-7 PLC program is situated in appendix 6, page 63 of the .

4.2 The Touch panel program

The first thing we did to program the TP is make a lay-out of the different screens we were going to program. We programmed four screens for the touch panel.

- The 1st screen its function is basically the start of the simulator. It has one big START button which sets the bit M0.0 in the safety check of the PLC program when it's pressed. You also continue to the next screen after pushing it. We also made a button to transfer the program from the PC to the TP during the programming, like that it was easy to test if our program was working properly. With the arrows you can change the contrast of the screen.

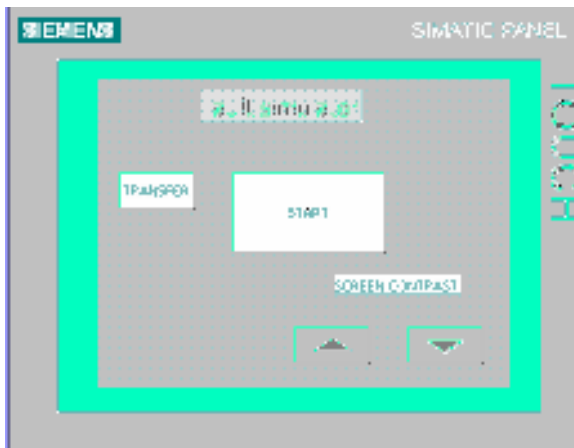

Screen n° 2 is being used to select the circuit. We have one button for each circuit, numbered from A until E. Each button is related to a marker in the PLC program so if you press it, that marker will be high. Instantly you'll continue to the 3rd screen. The arrow below is to go back to the previous screen and here it'll also reset the start button marker.

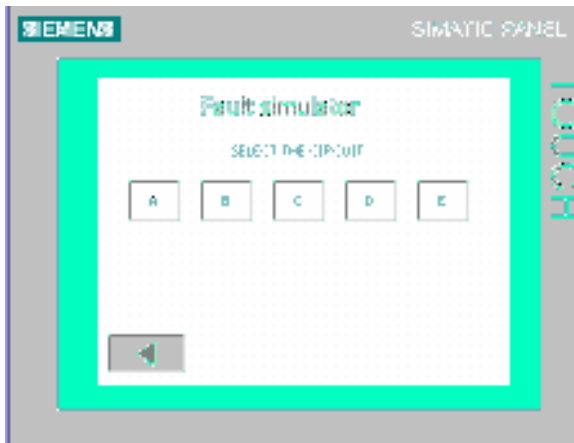

The third screen is the error selection screen, which has 13 buttons for the errors, another one to be able to choose “no error” and again a “go back” arrow like in the last screen. But the second function of that arrow is different, now it resets the circuit that we chose before.

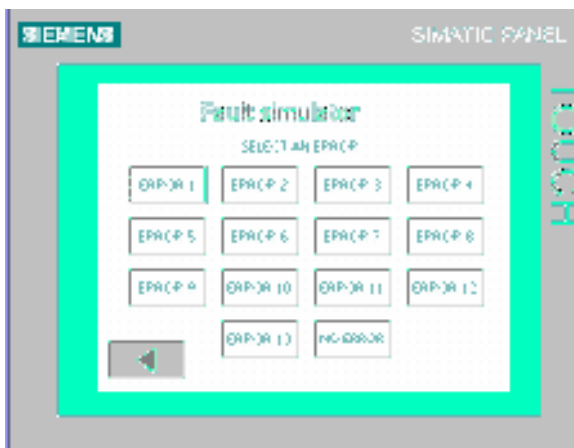

The last screen is just an information screen, what you can see on this screen depends on what was chosen in the last two screens. We have a box for the chosen circuit and another box for the chosen error.

For example, if we chose circuit A and error 7, in screen 4 we will be able to see that that circuit and that error is selected. This way you're sure you selected the right circuit and the right error. Screen n° 4 also has a “go back” arrow again, which 2nd function is to reset the selected arrow. When you press the stop button you'll go back to the 1st screen, the selected circuit and error will be resetted and the start button marker will be resetted.

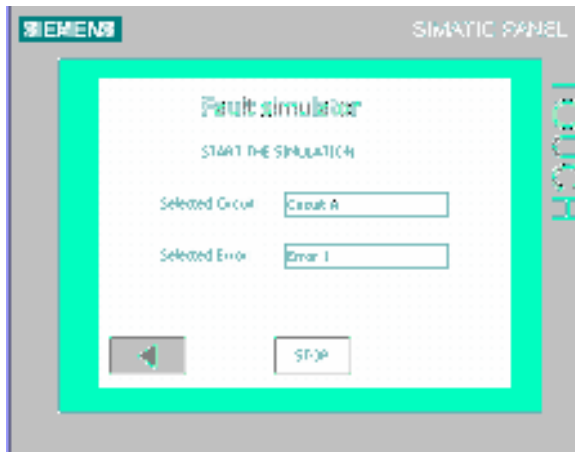

5 Testing and simulating

When the building and programming of the error – simulator was finished we just had to test if all the components were working and simulate the 5 circuits with their errors. For the first simulations on the PC we used a PLC available in the lab. When we thought everything was working like it should we moved the fault – finding simulator to that lab and connected its PLC with the PC and the TP. We simulated using the pushbuttons of the device but in the meanwhile we kept checking the PLC program on the PC. The final simulating we did with only the error – simulator and no PC.

5.1 Test of the device

Before we started with the testing we checked if the wires were connected in the right place. When that was ok we switched on the device with the power switch. On the inside we closed all the circuit breakers, starting with the 3-phased circuit breaker for the power circuit. After that we closed all the circuit breakers of the control circuit.

At that time we already witnessed a big problem. We noticed if circuit breaker 2 and 3 of the control circuit were closed together, a short - circuit occurred. This was obvious because the green signal light of the power supply stopped burning.

So we had to check all the connections with a multimeter. We thought that maybe one of the wires was connected wrong but after measuring everything seemed to be connected like the labels said. Since we didn't know where to search anymore we asked for help but nobody could help us because we didn't have an electrical diagram of the control circuit. When we drew that circuit a lecturer told us that somewhere the A1 and A2 of a relay coil had to be connected to cause the short – circuit. He said it had to be one of our wires that was connected wrong but we were sure that wasn't the case.

After searching for 2 days we finally found where the problem was located with the help of our promoter. It was the internal wiring of the thermal overload relays which was causing the short – circuit. It are special thermals because the contact 96 makes sure the power to the relays which controls the motors is interrupted by stopping the

current to continue its way to the A2 of the relay coil. Normally that contact is connected to the A1 of the relay coil. And in our control circuit, the external 96 contacts are connected to the + of the 24V supply. That's a very clear short circuit because the A2's of all relays are off course connected to the – of the supply. We solved this problem by simply cutting the 2 copper bars of both thermals like shown below.

LR2-K + LC-K
Pre-wiring scheme

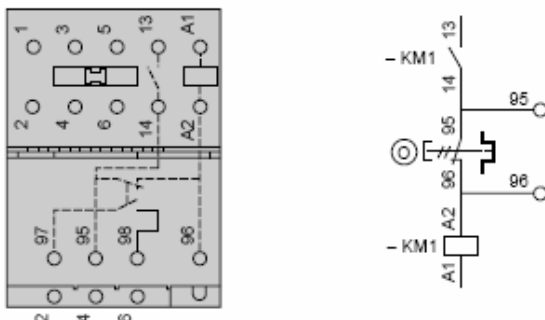

Note : If pre-wiring is not required, break off the 2 links located on the thermal overload relay.

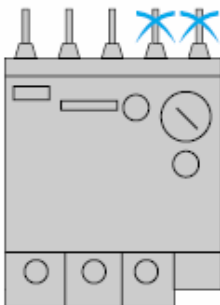

Now we could calmly close all the circuit breakers again and everything was all right. The supply stayed on and the power sign lights of the PLC and the safety relays were burning. So we finally could start simulating.

5.2 Simulation of the fault-finding device

The simulation was the final check of our project, it was the time to check if everything that we did from the beginning had been in the right way, or not.

When we started the simulation we first checked the safety check FC, and it didn't work. The safety marker bit didn't become high because the 2nd thermal didn't seem to be OK. However, when we checked the program some more we noticed that the output of relay K101 wasn't high either. And a NO contact of this relay is located between both thermals in the control circuit so it was logic the input of that thermal wasn't high. Soon after that we also found the reason why K101 wasn't excited. After we changed the hardware from the PLC in the lab to the PLC in our simulator we had forgotten to change the numbers of the outputs. That means any output could get high because all the numbers were different. When we changed that the safety check was OK.

Then we thought we finally could start simulating but when we selected a circuit and pressed the start button of that circuit anything happened. Only the first start button seemed to work but the other ones not. The reason was simple again. When we were wiring we thought the NO and NC contacts of each push button were connected internal. When we measured now we noticed that wasn't true so after we connected every pushbutton this problem was solved.

Afterwards we just had a little problem with a wire from measuring point 32 of the thermal contact. We measured no voltage there but we should. The wire was connected bad so we had to fix it and anything else. The reason of the bad connection was probably because we wanted to be too fast with rewiring the thermals after the short – circuit problem.

Now we could continue the simulation step by step, circuit per circuit and we almost didn't have any problems no more. The problems we had now were just some small programming mistakes.

When the simulation with the PC was done and we thought everything was working fine we did the final simulation with just the fault – finding device. We did this together with our promoter. We also used motors this time. All the errors and circuits which we programmed were working except for circuit E; the automatic star – delta.

6 Cost - price calculation

6.1 Components of Breva n.v.

Article Number	Reference/Description	Quantity	Unit Price EUR	Total Price EUR
E343079	PIT ES1.11	1,00 PC	11,28000	11,28
>	E-Stop pushbutton red/yellow without contactblock			
E367959	PIT ESB1.2	1,00 PC	9,84000	9,84
>	Contact block 2 NC contacts			
E340273	PIT EN 1.1P-20	1,00 PC	44,00000	44,00
>	Non-contact magnetic safety switch			
E272628	CONNECTOR PSEN	1,00 PC	6,60000	6,60
>	PSEN cable angleplug 2M			
E238852	PNOZ/X2P 24VACDC	2,00 PCS	104,80000	209,60
>	Safety relay PILZ			
E130986	LP4-K0610BW3	13,00 PCS	19,12160	248,58
>	Mini-contactor 24VDC coil low consumption			
E122718	LR2-K0306	2,00 PCS	18,60480	37,21
>	Mini-therm. rel. 0,8-1,2A 3P			
E367185	VBN-N12	1,00 PC	8,33000	8,33
>	Charge breaker + switch 12A 3P			
E176168	XB4-BA4322	2,00 PCS	6,64680	13,29360
>	Pushbutton D22 1NC red 0			
E176394	Consisting of: ZB4-BZ102	1,00 PC		
>	Contactbody 1NC screw clamp terminal			
E176455	ZB4-BA432	1,00 PC		
>	Head pushbutton D22 red "0"			
E1716167	XB4-BA3311	4,00 PCS	6,64680	26,59
>	Pushbutton D22 1NO green I			
E176393	Consisting of: ZB4-BZ101	1,00 PC		
>	Contactbody 1NO screw clamp terminal			
E176444	ZB4-BA331	1,00 PC		
>	Head pushbutton D22 green "1"			
E176988	ZBE-102	4,00 PCS	1,77480	7,10
>	Contactelement 1NG screw clamp terminal			
E320710	DR-SPS120W24V	1,00 PC	71,10000	71,10
>	1 ph switched power supply I:AC U24VDC 5A 1:88-132VAC + 176-264VAC			
E367187	006480	1,00 PC	23,00200	23,00
>	Circuit Breaker DX 6KA 3P C01 3 MOD			
E293520	005997	8,00 PCS	4,66860	37,35
>	Circuit Breaker DE CURVEC 3KA			
E148998	C2-A20/24VDC	3,00 PCS	6,55770	19,67
>	Put-in relay Releco			
E080139	ZB8	3,00 PCS	2,60000	7,80
>	Relayfoot ISKRA 8-pole IP20			
E010885	VOB-S 2,5 BLACK	100,00 M	0,18671	18,67
>	Flexible wire H07V-K 450/750V NBN C32-123			
E073993	VTB-S 0,5 BLUE	100,00 M	0,06288	6,29
>	Flexible wire H05V-K 300/500V NBN C32-123			
E005452	DZ5-CE005	300,00 PCS	0,00621	1,86
>	Cable shoe 0,5MM2 insulated white			
E005448	DZ5-CE025	300,00 PCS	0,00690	2,07
>	Cable shoe 2,5MM2 insulated grey			
E190641	636011	4,00 PCS	7,37180	29,49
>	Wire holder LINA 25 W60XH40 grey L:2M			
E300321	AE 1180/500	1,00 PC	143,67000	143,67
>	AE Enclosure 800X1000X300 RAL7035 + MOPLA 1D			
E098438	TS35	2,00 M	0,84000	1,68
>	SYM.PROF. 35X7,5 chromium-plate not drilled			
E352826	BE1M43D	100,00 PCS	0,05926	5,93
>	Cable Shoe PVC Insulated ring 1,5MM2 M4			
E176221	XB4-BVB4	2,00 PCS	5,77680	11,55
>	Signal light + LED D22 24VACDC red			
E176622	Consisting of: ZB4-BVB4	1,00 PC		
>	Signal light. + LED D22 24VACDC red			
E176670	ZB4-BV043	1,00 PC		
>	Red head for body with fitted LED			
E000789	3	1,00 PC	3,23070	3,23
>	Plug CEEFORM 3P+N+A 16A 380V			
			Sub-total:	1.005,78
			Port:	3,50
			VAT (21%):	211,95
			Total amount:	1.221,23

6.2 Components of Siemens NV

Article Number	Reference/Description	Quantity	Unit Price EUR	Total Price EUR
6ES7312-1AD10-0AB0	SIMATIC S7-300, CPU 312	1,00 PC	228,80	228,80
6ES7321-1BH02-0AA0	SIMATIC S7-300, DIGITAL INPUT	1,00 PC	114,40	114,40
6ES7322-1BH01-0AA0	SIMATIC S7-300, DIGITAL OUTPUT SM322	3 PCS	159,20	477,60
6ES7392-1AJ00-0AA0	SIMATIC S7-300, FRONT CONNECTOR	4 PCS	16,56	66,24
6ES7390-1AE80-0AA0	SIMATIC S7-300, RAIL L=480MM	1,00 PC	20,96	20,96
6ES7953-8LG11-0AA0	SIMATIC S7, MICRO MEMORY CARD	1,00 PC	57,12	57,12
6ES7972-0BB50-0XA0	SIMATIC DP, BUS CONNECTOR FOR PROFIBUS	2,00 PCS	36,00	72,00
6AV6642-0AA11-0AX0	SIMATIC TOUCH PANEL TP 177A 5,7"	1,00 PC	440,00	440,00
			Sub-total:	1.477,12
			Transportcosts:	15,00
			VAT (21%):	313,35
			Total amount:	1.805,47

6.3 Components of Stäubli Benelux NV, Division Multi - Contact

Article Number	Reference/Description	Quantity	Unit Price EUR	Total Price EUR
SLB4-G	4mm Safety Socket black	50 PCS	1,36	68,00
SLB4-G	4mm Safety Socket blue	50 PCS	1,36	68,00
			Sub-total:	136,00
			Port:	9,50
			VAT (21%):	30,56
			Total amount:	176,06

6.4 Components of B.A.G. - Plastics nv

Article Number	Reference/Description	Quantity	Unit Price EUR	Total Price EUR
HAN - TRES	Trespa plates 4mm thick, 700mm wide and 740mm heigh	5 PCS	/	140,20
			VAT (21%):	29,44
			Total amount:	169,64

6.5 The Total Price

TOTAL (VAT & Port excl.):	2.759,10 €
TOTAL (VAT incl.):	3.372,40 €

7 Conclusion

In February, when we were informed about all the things that had to be done to design this fault - finding device, we thought it would be impossible to finish. Even our promoter said it was possible we didn't finish and in the end he even told us he would be surprised if we finish.

Now, 4 months later, here we are with an operating fault - finding device. It was a big, very demanding project and we encountered many difficulties but still we managed to finish. We also learned a lot during this project.

We learned how to select components by looking at the characteristics. After that we gained experience in contacting the different suppliers and factories to ask for price offers and information. We also know better how to manage with the AutoCAD program now. We have experience in wiring an industrial enclosure. We improved our programming skills in Step 7 and learned how to program a Touch Panel. The last thing we improved is how to find mistakes in our design.

The project was also very useful for the school.

From now on the students will be able to work with a much safer simulator, which has much stronger stencils and measuring point connections. The measuring points will now also stay in position during the measurements, the same for the stencils. In that way it will be much more comfortable to do the tests.

Working with this device will be a good training for the students to improve their knowledge about the motors and the possible errors that could happen there.

When they will start to work in a factory and some fault occurs with a motor, they'll be much faster in finding the problem because they've worked with this error - simulator.

When something is wrong in the simulator, it'll be much easier to find the problem now because we labeled every wire. And if in the future somebody has to program the other circuits it'll be much easier for him then it was for us because we wrote the program in a way that it's more understandable then the old program

Bibliography

- Automation & Control Telemecanique: PLCs, HMI, drives, contactors,..., *Products*, www.telemecanique.com
- Elsen, J., Olaerts, A. en Daenen, M., *Labo Elektriciteit*, KHLim, IWT, Diepenbeek 2003 – 2004.
- Fabricante lider en reles, *Products*, www.releco.com
- *General / industry ▶ Direct current power supply units ▶ IPh switching power supplies 12V 24V*, www.erea.be
- Legrand België n.v., *Catalogus Elektrisch installatiemateriaal*, Diegem, 2000-2001.
- Legrand extranet, *Beveiliging en onderbreking Lexic ▶ Modulaire beveiliging ▶ Beveiliging van stroomkringen*, www.legrand-extranet.be
- Lemmens, J., *AUTOMATISERING Programmeerbare Logische Sturingen Siemens STEP 7 S7 – 300 DEEL 1 THEORIE*, KHLim, IWT, Diepenbeek 2003 – 2004
- Pilz – more than automation, safe automation, *Products and services*, www.pilz.com
- Rittal Enclosures, Cabinets, Boxes and Electronic Packaging. Approbations: UL, CUL, CSA, CCC, T, *Home/Products/Industrial Enclosures*, www.rittal.com
- Siemens AG, *Simatic Products for Totally Integrated Automation and Micro Automation Catalog ST70*, Nürnberg, 2005.
- Siemens AG, *Simatic Humane Machine Interface Systems Catalog ST80*, Nürnberg, 2006.
- Schneider Electric nv, *Algemene catalogus Telemecanique*, Brussel, 2004.
- Stäubli Benelux N.V. Division Multi-Contact, *Test & Measureline Multi-Contact*, Bissegem, 2005.
- Van Gansen, P. en Kuhn, M., *Leidraad bij het schrijven van een scriptie*, KHLim, IWT, Diepenbeek

Appendix 1: Circuits and errors of the existing fault - finding device

Nr.	Circuit	Error
1	B. Direct on/off switching	Thermal contact 95/96 interrupted
2	C. Direct on/off switching with 2 push-button units	Startswitch S1B without function
3	D. Sequential circuit 2 motors. On/off interlocking	Relayreel K1M interrupted
4	E. Sequential circuit, delayed switch-on	Relayreel K1M doesn't stay excited
5	F. Indirect rotation reversing of motors	Signallight without function
6	G. Direct rotation reversing of motors	In the overtakecircuit the NO contact is switched with a NC contact
7	H. Indirect rotation reversing of motors, with 2 push-button units	Makecontact bridges the mechanical interlocking
8	J. Pole change-over for motors with 2 separate windings, 1 direction of rotation	Two linewires in the powercircuit are switched
9	K. Pole change-over for motors with 2 separate windings, version 2	No reciprocal electrical interlocking
10	L. Pole change-over for motors with 2 separate windings, version 3	Timerelay in the controlcircuit is defect
11	M. Automatic star delta circuit	Defect contacts timerelay
12	N. Dahlander circuit, rotation reversing with contactor, 1 direction of rotation	Interruption of the linewires in the powercircuit
13	P. Dahlander circuit, rotation reversing with contactor, CW and CCW rotation	Switchcontacts in the powercircuit are defect

Appendix 2: Selection of the components

Here you can find the tables we used to select some of our components.

The safety relays

S. Severity of injury

S1 Slight (normally reversible) injury (i.e. cut or bruise)

S2 Serious (normally irreversible) injury

F. Frequency and/or exposure time to the hazard

F1 Seldom to quite often

F2 Frequent to continuous

P. Possibility of avoiding the hazard

(generally related to the speed and frequency with which the dangerous part moves and to the distance from the hazardous part)

P1 Possible under specific conditions

P2 Scarcely possible

- Preferred category for reference points
- Possible categories which can require additional measures
- Preferred category for reference points

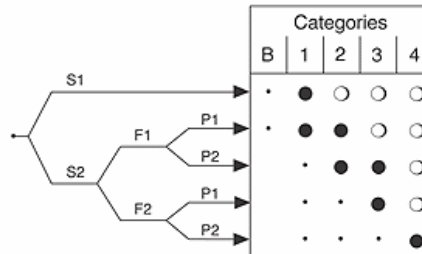

For the old simulator, the severity of injury = S2 (electrocution), the frequency = F2 because the students are being exposed to that risk all the time they're working with that simulator. And finally we end up in category 4 because it's scarcely possible to avoid the hazard. After checking which category we had to comply with, we checked all the different applications for safety relays. Our application was the first one of the different applications shown below. Out of the available relays we selected the PNOZ X2P because this was the only one which complied to risk category 4.

Emergency Stop Relays, Safety Gate Monitors



- ▶ PNOZ e5.11p
- ▶ PNOZ e5.13p
- ▶ PNOZ X2P
- ▶ PNOZ X1
- ▶ PNOZ X7

Emergency Stop Relays, Safety Gate Monitors, Light Barriers

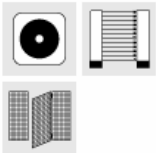

- ▶ PNOZ e1p
- ▶ PNOZ e1.1p
- ▶ PNOZ e6.1p
- ▶ PNOZ X2.7P/PNOZ X2.8P
- ▶ PNOZ X3P
- ▶ PNOZ X8P
- ▶ PNOZ X9P
- ▶ PNOZ X4

Emergency Stop Relays, Safety Gate Monitors, Light Barriers, delayed

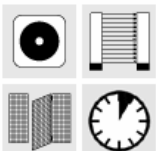

- ▶ PNOZ e1vp
- ▶ PNOZ XV1P
- ▶ PNOZ XV3P
- ▶ PNOZ XV3.1P

The contactors

Selection according to required electrical durability, in category AC-3 (U_e ≤ 440 V)

Control of 3-phase asynchronous squirrel cage motors with breaking whilst running.

The current broken (I_c) in category AC-3 is equal to the rated operational current (I_e) of the motor.

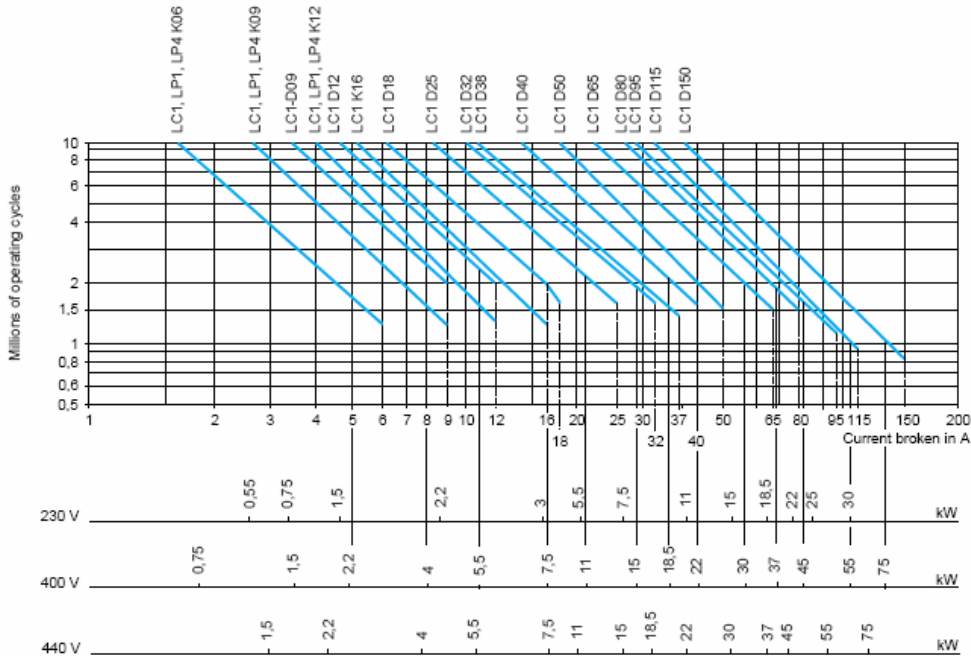

Operational power in kW-50 Hz.

3-pole low consumption contactors

Compatible with programmable electronic switches.

LED indicator lamp optional (supplied outside LP4 K06 and LP4 K09).

Wide range coil (U_c = 120 Vdc) supports direct start, maximum 1.8 W.

Rated power ratings of 3-phase motors at 50 Hz in category AC-3		Rated operational current in category AC-3 at 440 V		Interlocking auxiliary contacts	Breaker rating, to be completed by adding the voltage code [?] [?]	Weight
220 W	550 W	4 (K06)	9 (K09)			kg
220 W	470 W	4 (K06)	9 (K09)			

Breaker class-combinations

1.5	2.2	3	9	1	--	LP4 K06/09	0.325
				--	1	LP4 K06/09	0.325
2.2	4	6	9	1	--	LP4 K06/09	0.325
				--	1	LP4 K06/09	0.325
3	5.5	4 (440)	9	1	--	LP4 K06/09	0.325
				--	1	LP4 K06/09	0.325

[?] Standard motor rated voltage (for other voltages, please consult your Regional Sales Office).

[?] 3-pole only, see also 127 V AC, 115 V AC.

Code	10	20	24 (2)	30	36	45	55	65	75	85	100	110	125	150	175	200	225	270	300
Code	J0	Z0	B0	F0	E0	80	S0	H0	F0	G0	P0	E0	L0	M0	D0	F0	M0	M0	M0

Code [?] voltage suppression device standard, [?] to be added together. Example: J0B.

Low consumption contactors (U_c = 120 Vdc, 1.8 W)

Code	10	20	30	45	75	110	150
Code	J00	Z00	B00	E00	S00	F00	G00

[?] For LP4 K06, when connected to an electronic device or device in series with the terminals and used at 230 V only, a contact rated voltage code Z2, or contact rated voltage code Z3, as per the requirements for the intended voltage class.

Protection components

k thermal overload relays, adjustable from 0.11 to 16 A

3-pole relays with screw clamp terminals

These overload relays are designed for the protection of motors. They are compensated and phase failure sensitive. Resetting can either be manual or automatic.

Direct mounting: under the contactor for versions with screw clamp terminals only; pre-wired terminals, see pages 22008/2 and 22009/3.

Separate mounting: using terminal block LA7-K0064 (see below).

On the front face of the overload relay :

- selection of reset mode: Manual (marked H) or Automatic (marked A),
- red pushbutton: Trip Test function,
- blue pushbutton: Stop and manual Reset,
- yellow trip flag indicator: overload relay tripped.

Protection by magnetic circuit-breaker type GV2-LE, see pages 24540/2 and 24543/2.

Relay setting range	Fuses to be used with selected relay			Reference	Weight kg
	Maximum rating				
	Type				
	aM	gG	BS88		
A	A	A	A		

Class 10 A (the standard specifies a tripping time of between 2 and 10 seconds at 7.2 In)

0.11...0.16	0.25	0.5	–	LR2-K0301	0.145
0.16...0.23	0.25	0.5	–	LR2-K0302	0.145
0.23...0.36	0.5	1	–	LR2-K0303	0.145
0.36...0.54	1	1.6	–	LR2-K0304	0.145
0.54...0.8	1	2	–	LR2-K0305	0.145
0.8...1.2	2	4	6	LR2-K0306	0.145
1.2...1.8	2	6	6	LR2-K0307	0.145
1.8...2.6	4	8	10	LR2-K0308	0.145
2.6...3.7	4	10	16	LR2-K0310	0.145
3.7...5.5	6	16	16	LR2-K0312	0.145
5.5...8	8	20	20	LR2-K0314	0.145

Tripping curves

Average operating time
related to multiples of
the current setting
Class 10 A

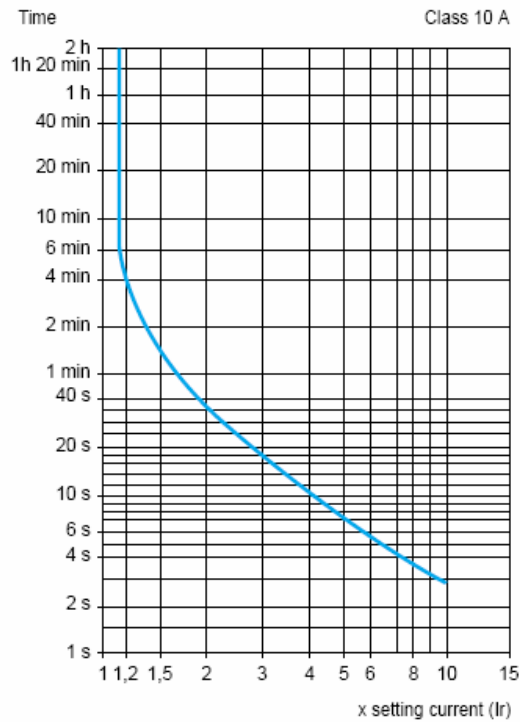

Balanced 3-phases operation,
from cold state

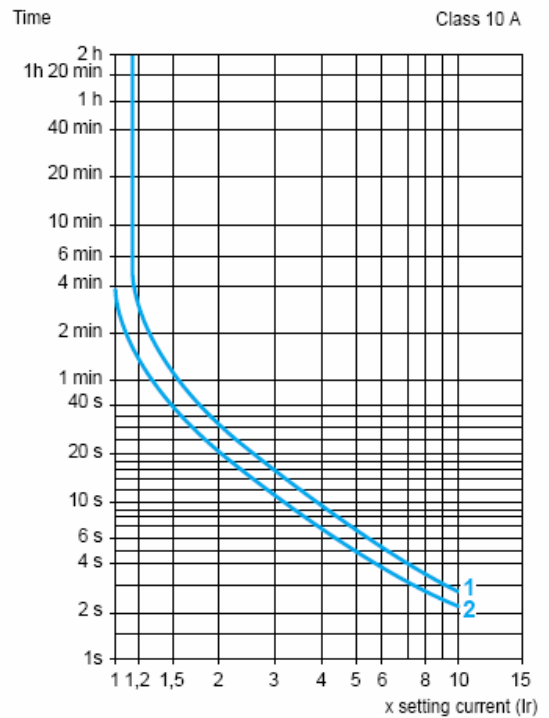

Balanced operation with 2 phases only,
from cold state

- 1 Setting : at lower end of scale
- 2 Setting : at upper end of scale

The circuit breakers

DX 6 10 kA Curve C
magneto-thermische automatische schakelaars
Driepolige 400 VQ



Ref.	Verp.	Nominale stroomsterkte (A)	Onderbrekingsvermogen		Aantal modules van 17,5 mm
			NBN C 61-898	IEC 60947-2	
064 80	1	1	6	10 000 A	3
064 81	1	2	6	10 000 A	3
064 82	1	3	6	10 000 A	3
064 83	1	4	6	10 000 A	3
064 84	1	6	6	10 000 A	3
064 86	1	10	6	10 000 A	3
064 88	1	16	6	10 000 A	3
064 89	1	20	6	10 000 A	3
064 90	1	25	6	10 000 A	3
064 91	1	32	6	10 000 A	3
064 92	1	40	6	10 000 A	3
064 93	1	50	6	10 000 A	3
064 94	1	63	6	10 000 A	3

DE 3 Curve C
magneto-thermische automatische schakelaars
Eenpolige 230/400 VQ



Ref.	Verp.	Nominale stroomsterkte (A)	Onderbrekingsvermogen		Aantal modules van 17,5 mm
			NBN C 61-898	IEC 60947-2	
059 96	1	1	3	-	1
059 97	1	2	3	-	1
059 99	1	4	3	-	1
060 00	1	6	3	-	1
060 02	10	10	3	-	1
060 04	10	16	3	-	1
060 05	10	20	3	-	1
060 06	1	25	3	-	1
060 07	1	32	3	-	1
060 08	1	40	3	-	1

Appendix 3: The price offers

Appendix 4: Drawings of the new fault - finding device

On the A3 papers you find behind this page we printed the drawings of the 5 circuits but also of the entire door. That last drawing is printed with the holes of all the circuits and also the holes of the pushbuttons and emergency stop. The location of the touch panel is also defined on that drawing. They are ordered in the following order:

- circuit A: Dahlander circuit, rotation reversing with contactor, 1 direction of rotation;
- circuit B: Direct on/off switching;
- circuit C: Pole change-over for motors with 2 separate windings, version 2;
- circuit D: Sequential circuit 2 motors. On/off interlocking;
- circuit E: Automatic star delta circuit;
- the door of the enclosure

Appendix 5: Pictures of the new Fault finding device

The outside of the enclosure



Close - up of the push buttons & E - Stop

Close - up of the Touch Panel



The magnet of the PSENmag

The actuator mounted on the L - profile



Both the elements together



The PLC



The inside of the enclosure



The wiring of the enclosure

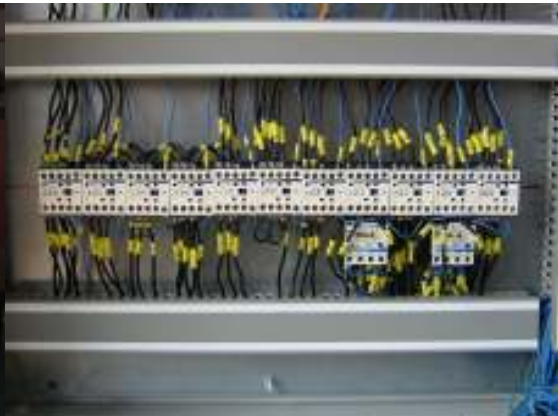

Appendix 6: The PLC Program