

This is a peer-reviewed author manuscript version of the following article: Ciurana, J., Garcia-Romeu, M-L., Ferrer, I.& Casadesús, M. (2008). A model for integrating process planning and production planning and control in machining processes. *Robotics and Computer-Integrated Manufacturing*, 24 (4), p. 532-544 Available online at <https://doi.org/10.1016/j.rcim.2007.07.013>

© 2008. This manuscript version is made available under the CC-BY-NC-ND 4.0 license <http://creativecommons.org/licenses/by-nc-nd/4.0/>



## A MODEL FOR INTEGRATING PROCESS PLANNING AND PRODUCTION PLANNING AND CONTROL IN MACHINING PROCESSES

### Authors:

Ciurana, J. (1), G.-Romeu, M.L. (1), Ferrer, I. (2), Casadesús, M.(2)  
(1), Department of Mechanical Engineering and Industrial Construction, University of Girona  
(2), Department of Business Administration, Management and Product Design, University of Girona

### Abstract:

The goal of process planning is to propose the routing of a previously designed part and results in a sequence of operations and their parameters. It concerns and requires detailed information about the process. The goal of production planning, on the other hand, is to schedule, sequence and launch the orders introduced on the routing sheet into the job-shop according to the enterprise's strategic goal and the actual conditions of the production plant. The goals, information and decisions taken in process planning and production planning and control are often very different, and, because of that, it is very difficult to integrate them.

The objective of this work is to develop a model that can be applied in the future to the development of an integrated process planning and scheduling tool using and Integrated DEFinition (IDEF) methodology to design an activity model, which integrates process and production planning in metal removal processes. An activity model will be used to develop a system that allows the user to plan the process and the production at the same time in collaborative engineering work. To design the activity model, a wide range of parts were evaluated and processed in an actual job-shop factory. Several activities were developed in detail to be tested in real cases, and an example of one of them is introduced in this article.

**Keywords:** Machining processes, Computer Aided Process Planning (CAPP), Production and Planning Control (PPC), Activity model, Sequencing in machining processes

### Corresponding author:

#### Joaquim de Ciurana

Department of Mechanical Engineering and Industrial Construction. University of Girona

Address: Av. Lluís Santaló s/n. 17071 Girona. SPAIN

Tel: 34 972 418265

Fax: 34 972 418098

E-mail: [quim.ciurana@udg.es](mailto:quim.ciurana@udg.es)

# A MODEL FOR INTEGRATING PROCESS PLANNING AND PRODUCTION PLANNING AND CONTROL IN MACHINING PROCESSES

## 1. Introduction

The goal of process planning in a production environment is to select and define, in detail, the process involved in transforming raw material into a specific end product with a given shape and certain specifications. In other words, to determine the feasibility of processes and operations that, together with the necessary parameters, assure the finished manufactured part is obtained without any problems [1]. The purpose of production planning and control (PPC) is optimising the flow of material and the use of the machines involved in manufacturing, taking into account various management goals like reducing the work in progress, minimizing shop floor throughput and lead times, improving responsiveness to changes in demand and improving delivery date adherence. Typical PPC system functions include planning material requirements, demand management, capacity planning and the scheduling and sequencing of jobs.

Needless to say, both process planning and production planning have complementary goals in order to improve continuing company productivity and, eventually, competitiveness. That said, optimal manufacturing routes, from the point of view of process planners, are often very different from the optimal routes in the opinion of production planners. Their respective goals can be as different as reducing the cost of each part in the first case, and reducing the time a specific machine is occupied in the second. In addition, these optimal routes can vary over time since they depend on the current situation of all the factors involved in the production process (availability of machines, parts, workers, etc.). Nevertheless, although process planning and production planning do not share all of the same objectives, their objectives are complementary in the sense that they should lead to a single optimal solution that shortens the manufacturing cycle as much as possible while increasing production flexibility and, in turn, company productivity.

In order to be able give optimal manufacturing orders at any given time regarding, for example, production times or costs, automated systems to assist in process planning, also known as Computer Aided Process Planning (CAPP), will be designed to varying degrees of success. These CAPP systems were originally developed as a link between design and manufacturing, filling the existing gap between CAD (Computer Aided Design) and CAM (Computer Aided Manufacturing) [2, 3] and responding to the need for MRP (Material Requirement Planning) to work with standard and optimised routes which can be used in production planning. The inputs in these systems are the technological variables involved (tolerances, materials, etc.) that allow the calculation of a specific output: the routing, which is a sequence of manufacturing operations containing details about the depths of pass, the speeds, the dimensions, the assembly steps, the tools, etc.[4]. However, the fact that these CAPP systems are completely separate from the management variables under the control of the production planner (stocks, available machines, workers, etc.) means the sequence provided by the system must be the optimal one according to the defined objectives. Even so, such an optimal process plan may not guarantee the best way to manufacture the part in the plant at a specific moment, as it could lead to the overload, or under use, of some machines, with subsequent bottle-necking. Generally, and depending on the severity of these bottlenecks, this problem is reduced in what [5] calls production rescheduling: the CAPP system is required to generate alternative routes and to implement them during the following shift or the following day according to the production planning and control analysis. For this reason, if the CAPP system does not take into account the existing management restrictions, it is recommended to generate more than one plan [6, 7].

Until now many studies have undertaken to individually optimise the two tasks, process planning and production planning, individually. The process planning problem has only been partially analysed in many research studies, among which the following stand out: a) joining process planning with the part design [8]; b) improving the choice of machining process parameters for cylindrical parts [9] or for prismatic parts [10]; or finally c) optimising the sequence of operations [11-13].

The same has happened with respect to production planning and control (PPC). Many research studies have focused on specific aspects of the problem, leading only to partial solutions which do not

necessarily correspond to the overall best solution to the problem. Some of these research studies have used the three 'classic approaches' of production organisation according to [14] - JIT, Manufacturing Resource Planning (MRP II) and Theory of Constraints (TOC) - and have worked on emerging techniques such as Workload Control (WLC), Constant Work In Process (CONWIP) and Paired cell Overlapping Loops of Cards with Authorization (POLCA). Some of the new approaches are the result of MRP leading to further Advanced Manufacturing Technology (AMT) such as Enterprise Resource Planning (ERP), Advance Planning and Scheduling (APS) Systems and Workflow Management Systems (WMS).

From that research it can be inferred that effective paths of communication and integration between CAPP and PPC are essential. [5] has called attention to the weak links existing between information systems and the CAD-CAPP-PPC systems in the majority of companies. He has also pointed out that carrying out this integration will require work on three basic aspects: a) the complete integration of computer aided design systems, technological preparation of production systems (like CATIA, ProEngineer, etc.) and planning management systems (such as MRP/ERP, SAP, BAAN, etc.); b) integration through universal standards of data exchange (for example, STEP and IGES); and finally c) the use of technological and constructive features.

That said, and despite taking into account the efforts made by [15-19], very few studies have attempted to integrate these two fields of research. In fact, the effective integration of process planning and production planning and control is not a trivial matter. Both processes work with a more than considerable amount of data, sometimes shared, but at times with nuances in the definitions that make the integration complex. Process planning resource databases are static and are usually not updated to reflect the situation on the shop floor. Production planning and control, on the other hand, is time dependent and deals with dynamic environment. In addition, process planners are generally focused on operations carried out on individual parts, while production planning and control systems deal not only with multiple parts, they also deal with multiple products to be manufactured in the same system.

At this point it should be clear that the purpose of this study is to establish a frame of reference or model where process planning is integrated with production planning so that their objectives are shared and made compatible to provide a joint solution with better global product manufacturing results and time and/or cost reductions. This model was intended to be the basis for the creation of future management systems that integrate process planning and production planning and control.

Achieving this goal will require correctly modelling all the actions carried out in both fields even though they often concern two very different areas of the company: design and management. Therefore, this study begins by examining the various steps or actions involved from the moment the requirements of a part to be manufactured are known until it is produced and launched into the market. Knowing the structure and type of information required to carry out each activity as well as the functions of each action are essential for the correct integration of the two planning tasks. Consequently, IDEF modelling techniques will be used to introduce an integrated model of process and production planning.

Based on the design and definition of the previous reference model, various programme modules have been implemented to carry out specific actions. These modules are supported by a database which takes into account a detailed analysis of the two fields of application. To test its applicability, and to provide an example, one of the designed modules will be presented in this article.

## **2. Methodology research**

The usual way to divide up process planning tasks in manufacturing companies is to hand over the plans to the manufacturing process experts who then specify the procedures to make the product. The process planners, using their experience and knowledge, generate instructions for the manufacture of the products based on the design specifications and on installation and operator availability. The fact that there are few experienced process planners and that, when faced with the same problem, different process planners would probably come up with different plans are indications of the heterogeneity that exists in Process Planning [20]. Despite depending on individual planners, process planning, whether manual or automatic, can be divided into various steps, phases or stages, as

several researchers have demonstrated [3, 21-23]. In short, consistent and correct planning requires knowledge of manufacturing processes and experience.

The very same is true in production planning: the planner's knowledge of production planning is fundamental. Thus, we are faced with two planning problems – one concerning the process and the other the production – where the results generally depend on the relative capabilities of two independent planners.

In order to develop our model, which will attempt to establish a single decision-making process leading to a good global solution, the planning behind various manufactured parts must be monitored and analysed. A model for all the types of analysed parts has been designed using the empirical evidence and is presented in this article.

Needless to say, the working process developed to carry out this research has been too painstaking and tedious to be dealt in an article. For that reason, explaining it through an example seems most appropriate. The example used to explain the methodology will attempt to represent all the steps required in the integrated planning of a product. A conventional sequential procedure is generated based on different case studies elaborated by industrial planners. The example shown is one of them. The activity model created uses all the evaluated parts to include all the know-how generated in the research. The relationship between the steps and activities in the activity model is only established after studying different cases. It will be presented at the end of the example, in Section 3.

## 2.1 An example of process planning: Activities involved

When analysing the planning process for a set of parts, one easily recognises that there is a set of repeated actions which, if they are important enough, will form part of the developed model. This example will analyse which actions make up the planning of a specific part in order to include them in the model. As these actions are "identified", they will be commented on.

Starting with the example, the first step begins with customer requirements, such as those defined in the diagram in Figure 1. The planning work begins with the designed part, represented in a drawing, and ends with the machined part obtained from the process. Throughout the entire planning process, any variables that can be involved in either the process planning or the production planning must always be kept in mind.

First of all, a decision must be made about the raw material. Such a decision probably depends on how many parts will be produced. For our example, one hundred parts were produced, so the job started with a 115x115 mm preformed bar which was cut at 35 mm. This implies machining all the faces of the part. This step can be called *determining the raw material*.

[Caption figure 1]

The geometry of the part means performing global operations on the raw material. First, to perform the geometry contour on the part to 110x110, it is necessary to drill the four holes, drill the central hole and isolate the geometry in the centre. Performing accurate operations should not be a problem because geometrical tolerances are built in. This step is called *volume approximation*.

When the drawing is studied, it might be discovered that the previously mentioned volume approximation operations are not enough and that other operations are needed to define the shape and dimensions with more precision. This stage, called *volume accuracy*, is required because some operations are only suitable for the rough stages, not for the finishing ones.

When real dimensioning and tolerance are obtained, it is important to check the true shape, the form (e.g., cylindrical), the position (e.g., coaxial) and the orientation (parallel) requirements. This step is called *geometric volume*.

At this stage, more mathematical tasks are required. For any given operation, the conditions are studied and various solutions are proposed. Table 1 shows an example related to the four holes to be

drilled and to the central isolated geometry in Figure 1. The table shows the cost and time for one operation (i or k) depending on which machine is used. In the example the two operations under consideration can be carried out in four different ways.

[Caption table 1]

In this stage many aspects of the operation must be considered.

- a) The information about all the machines, tools and fixtures of the shop floor are used in this step.
- b) The cutting parameters of each operation are decided upon by considering the properties of the material and the tools.
- c) Each line represents one operation alternative, with machine, tool and fixture selected. An alternative is represented, but is not chosen as a solution.
- d) The cutting machines, tools and machines allow the total cost and time to be calculated.

$$C = C_1 T_p + C_2 T_c + C_3 \frac{T_c}{T_l}$$

Where total cost is C, cost per hour related to indirect labour, cutting labour, and tool labour are  $C_1$ ,  $C_2$ ,  $C_3$ , respectively, and non production time, cutting time and tool life time are  $T_p$ ,  $T_c$  and  $T_l$ , respectively.

- e) Some operations can be rejected due to the high cost or the long time involved.
- f) The information column is for observations and information to be taken into consideration if the technology requires one operation to be performed before or after any other operation.

The results can be shown in cost and time matrices. For each matrix the rows are the operation alternatives and the columns are the machine alternatives. So element  $A_{ij}$  of the matrix represents the cost or time for operation "i" with machine "j". This step is called *operation* [24].

The next step (*Sequence operations in machines*) is also very mathematical. In it different routings are created. The routing must be controlled and information about it like (O4M2T5F7+O1M1T1F1+...) means this route is done by adding operation 4, 1 and so on, and that operation 4 is done by machine 2 with tool 5 and fixture 7. These codes are related to machine, tool and fixture data - very important information for the decision.

Each routing represents an alternative way to produce the part with the cost and time calculated. The previously calculated procedure is considered, and other costs like indirect holding costs, set-up costs, waiting costs, and the cost of transport between machines i and j are also calculated.

$$C = \sum C_4 T_{ij} + \sum C_5 T_i + \sum C_6 T_{ei}$$

Where indirect holding, set-up and waiting labour costs are  $C_4$ ,  $C_5$  and  $C_6$ , respectively, and set-up in the "i" machine, transport between the "i" and the "j" machines and waiting for the "i" machine times are  $T_i$ ,  $T_{ij}$  and  $T_{ei}$ , respectively.

These costs can influence the preference chosen from the table created in the operation step. During the transfer of a part between two machines, set-up can change the most suitable operations for others, so time is not lost waiting for a free machine.

At this point, all possible routes leading to the manufacture of the part ordered by the customer are available. Now it must be decided which the best route to follow is according to the existing management parameters: material in stock, occupied machines, etc. This is the specific objective of production. The appropriate manufacturing resources are assigned to follow and complete the routing and plans are made to launch production in the production plant. As a result, the routing is converted from a generic list of machining operations and features into a list of operations assigned to a particular machine at a particular moment. In this way details such as when an operation is expected to be finished and at which moment the machine will be freed up are known.

Production planning and control requires having all the information from the production plant. This information should refer primarily to the plant occupation as well as factors such as the importance of the customer enquiry stage, the company size, the degree of customization and the shop floor configuration, all specific to a machining manufacturing environment.

Considering only terminological aspects, for many authors the process involving the part used in the example is a scheduling topic rather than a planning one. In this sense, and according to [25], *planning* in a company is usually concerned with higher level decisions such as what and where to produce, and deals with the longer time horizons of economic objective functions like profit maximization. *Scheduling*, on the other hand, is concerned with lower level decisions such as sequencing, and deals with the shorter time horizons of feasibility functions like meeting the production targets set at the planning level. Recently, the development of methods for the efficient integration of planning and scheduling has received a great amount of attention in the industrial sector and in the research community, largely because of the challenges and the high economic incentives involved. To sum up, planning and scheduling are processes that transform the independent requirements of a finished product with a delivery date, resulting from forecasts and customer orders [26], into executable manufacturing schedules and procurement requirements for raw materials.

Continuing with the proposed example, when manufacturing a group of parts it is first necessary to assign the work load of all the possible manufacturing routes for the part to the actual machines of the production plant. This activity, known as *disaggregate routing sheet for workshops*, contains an important element that distinguishes it from the “classic” way of assigning done by many production systems: it takes into account the current operating situation of the company. In other words, this phase must be carried out every time a group of parts is to be manufactured, keeping in mind the available machines, the available workers, the tools, the lines, etc.

At this point the system has to generate alternatives and evaluate the capacity of the workshop. Here another very important point must be emphasized: the alternatives do not only refer to the group of parts to be manufactured; they refer to all the parts being produced at that moment in the company. It is therefore necessary to know what is being manufactured, which machines can be switched to another type of production, which groups of parts can be divided and which ones cannot, etc. These two phases are called *generate alternatives* and *evaluate capacity of workshops*.

Obviously the best alternative must be chosen before the next two phases which we have called *sequence processes* and *generate production plan*. These two phases provide the exact manufacturing sequence for each machine and, more specifically, the best option for producing a specific group of parts ordered by the customer. Data like the shop floor lay-out, the average waiting time and the average set-up time for each machine must be taken into account. These can be obtained from a historical review or a calculation of the shop floor capacity.

As can be observed in the example, there are two clear planning phases: process planning, which must only be recalculated every time new machines or tools are introduced into the company, and production planning, which must be recalculated every time new orders are received since they can change not only what is already planned but also what is being produced at that moment. This is called rescheduling. Traditionally, company decisions flow in a top-down manner, leaving less degree of freedom at lower levels for rescheduling, and therefore leading to frequent revisions of targets set by the upper levels [25]. Contingency measures to integrate rescheduling have been ignored in most of the published studies.

## **2.2 An example of process planning: Information involved**

Developing the example has clearly demonstrated how each activity requires a set of information, or input, which it then converts into output according to the available resources and the controls used. Although at first it is only important to establish which activities should be carried out, subsequently a very detailed analysis of the information required for each activity must be made. For example, in the analysed case, and taking into account only the part referring to process planning, the most important information used is shown in Figure 2.

[Caption table 2]

In fact it can be demonstrated that in the various steps of the sequential system being followed, it was necessary to have data concerning the machines, the fixtures, the tools or the specific parameters of the productive plant: distances between machines, size of the group, etc. The information required in each of these steps is different, as are the reasons why it is required.

In order to model these sequential steps, an activity model directly transforming steps to activities has been used. The nature of some of the required information can be known intuitively from Table 2, even though, in the development of the activity model, it is more important to deal with the structure of this information and how it is related than with the information itself in a detailed way.

Further on it will be necessary to integrate all those data in a system capable of supporting, managing and relating all the information used throughout the decision model proposed in the present study.

### 3. Proposed activity model

It is believed that the development of a tool for any practical use should be based upon a thorough understanding of the application domain [27]. This will be achieved using a graphical method for “modelling” a system, IDEF. Integrated DEFinition (IDEF0) is a method designed to model the decisions, actions, and activities of a system. This technique is used in the early stages of problem definition and it provides a mechanism for communicating complex concepts through a simple syntax of boxes and arrows.

This model is enough flexible to be easily integrated within any MRP or ERP existing system. In fact, they use the same data. In order to get an efficient implementation, the system must use the same database that the previous production planning software. This is the only way to avoid the duplication of input data and the effort to updating the model continuously. Otherwise, if the system is not integrated it will be absolutely useless.

The first step in developing an IDEF model is to establish the purpose and the viewpoint of the model. The aim is to develop an integrated planning system that will aid process and production planners. The purpose of the developed model is to integrate the process and the production domains. The required input to the system is the drawn part. From this information the system should output the production order. The controls to determine the output are: times, total cost, capacity, databases and knowledge. And the mechanisms to achieve the output under those controls are: machines, fixtures, tools, shop floor, and computation systems. The initial level, A0 (Fig. 2), defines the overall work to be done, though in the first level it is more detailed.

[Caption figure 2]

At this point it must be said that, in addition to the set of parts analysed, the present model has been developed using some of the ideas pointed out by González [28] in the only model found in the literature that pursues the same goal as this study.

Figure 3 displays the first stage of the decomposed model, consisting of two actions or activities: *Process Planning* (A1) and *Production Planning* (A2). Activity A1 is related to the production activity through the cost, the time and the routing.

[Caption figure 3]

The *process planning* activity (A1) is broken down into five sub activities and presented in Figure 4. The actions summarized in Table 2, which make up part of the example developed, must be represented throughout the different levels of the IDEF representation, and in this case are included at the level shown in Figure 4. All of those activities must be preceded by a verb and each activity must have inputs, outputs and controls, as suggested by the IDEF methodology.

Figure 4 displays sub activities A11 to A15 and the data flow. *Determine raw material* (A11) sets the dimensions and the shape of the perform (material at the initial stage) based on the dimensions and geometry of the part. Next, activity A12, *Determine options to operation and machines*, elaborates a

list of operations for each geometric volume to be removed. All the operations involve a fixture and a machine. Creating a sequence for the operations carried out on the same machine, ordering them from the best to the worst, is the task of activity of A13, *Sequence operations in machines*. At this stage, activity A14, *Determine tools and conditions*, is possible. In this sub activity, based on A12, the tool is selected and its characteristics (cutting speed and feed rate values) are established. Finally, activity A15, *Documentation*, is where all the information created in the process activity is put together and aggregated.

As can be demonstrated, the example analysed in this article can be included very well in the model presented, as can the other parts analysed.

[Caption figure 4]

Activity A2 is based on the characteristics of the production plant and is related to the process. The development of this activity is presented in Figure 5. This figure displays A2, *activity decomposition*, where the production planning activity is also broken down into five sub activities. The first sub activity at this level is A21, *Disaggregate routing sheet for workshops*. It consists of disaggregating the information of the routing to make plans for the different workshops. After that, alternative operation sequences can be generated in the workshops. This corresponds to activity A22, *Generate alternatives*, which generates several possible routings. The third activity at this level is A23, *Evaluate the capacity of workshops*. This activity, based on A21 and A22, approves the routings that, under the given conditions, can be carried out in the production plan. Thus, in the next activity, A24 *Sequence processes*, the processes are sequenced by machines and plant conditions, considering all the characteristics, both static and dynamic. Finally, the production plan has to be generated in activity A25, *Generate production plan*. This last activity defines a complete, efficient and effective production plan that creates a production order. This plan contains the process characteristics (machines, tools, fixtures, transport, set-up, etc.) and the production characteristics (sequences in the machines and in the plant) of all the products to be machined.

In the proposed model it can be clearly seen how many different possible alternative manufacturing routes are proposed in process planning. In fact, some previous studies have placed great importance on the fact that process planning offers one optimal solution. However, it is important to offer a range of possible solutions for the production of a part given that the “management” circumstances can easily vary. When alternatives are mentioned, is it in reference to all the possible routes or only to the best? Needless to say, the model is open to all alternatives, indicating that in order to assure the optimal route to be used at any given moment, all possible routes must be generated. Nevertheless, implementing the model in a computerized system, and taking into account the number of variables to be dealt with, the computational capacity and the desired response time, will limit the computation of the available manufacturing routes to a more or less high number. This will occur in many of the actions established in the model. Therefore, the model has been proposed as a reference that encompasses all the possibilities, which are only limited by the capacity of the system implementing them.

[Caption figure 5]

In the same way that a specific part of the model has been briefly explained, and without entering into too much detail, the model is much more extensive, given that each activity has been developed in much more detail than it was in the presented model. Even though the information presented in this article is complete enough to understand the developed model in general terms, the entire version of the developed model can be consulted in the online version of the article (see electronic Annex 1).

#### **4. Practical implementation**

The IDEF0 model developed and presented in the previous section has been used to clearly and explicitly define the activities required to integrate process planning with production planning. In this sense the IDEF model is particularly strong: it clearly defines the information used in each activity as input, output, control or resource, deals step by step with all the problems of integration and develops the system in a modular way, leading to total integration.



The IDEF model has been used to develop methodologies and systems to break an activity down individually. Once it has been divided, it is easy to integrate it with other potentially related activities. The activity model itself clarifies these relationships.

Many of the activities have already been developed and some of them have been presented in previous studies [24, 29]. Because the size of the programmes developed does not allow them to be presented in detail here, only one of the programmes integrating various activities of the model will be presented as an example. The same numbering used in the presented model has been used for each activity in this example.

The example we have presented and implemented brings together various activities from different levels, demonstrating how the model can be adapted to the goal of the implementation as long as the inputs and outputs of the implemented system, as well as its objective, respect the model. If not, its subsequent integration into a larger-capacity system would not be possible. The example presented includes the following activities of the model: activity A124 related with activity A12, and activity A131 depending on activity A13, with activity 14 from the second level, as can be observed in Figure 6. As explained below, these activities were developed previously and independently.

[Caption figure 6]

First, a system and methodology corresponding to a sub level of activity A12, *cost estimating* (A124), were developed to compute the time and cost of a process: a machining operation. However, the effectiveness of this tool depends to a great extent on the data about machines, tools and equipment found in the database.

In activity A131, *determine the precedence relationship*, this machining operations was clearly determined, resulting in a precedence table for various machining operations. This table is used to decide the order of operations for a part, and to create several possible routings [24].

In the activity *determine tools and conditions* (A14) a computational system was defined for the appropriate cutting conditions. A computer system was developed to assist in the optimised calculation of the feed rate and depth of cut in a machining process. The methodology has been compared to the different examples of activity A131. This activity has been repeated for individual cases requiring high speed machining [30].

The work carried out in the three previous systems has led to a system that integrates the activities mentioned as well as the following three activities - determine options to operations and machines (A12), sequence operations in machines (A13) and determine tools and conditions (A14) – and at the same time integrates their sub activities, as it is shown at Figure 6 central zone.

Designing and implementing the system in a computer programme provides the format of the routing format with its corresponding operation sheets and obtains possible routing alternatives (with their corresponding operation sheets) for the same part.

In this study it has been established that:

- Routing consists of the set of operations required to manufacture a part. These operations are organized into phases (machines) and sub phases (flanging on each machine). The type of machine and the time and global cost of each operation (remember A124) will be assigned to each operation. Other information on this routing includes the lot and the sequence of operations.
- The operation sheet consists of the details about parameters needed to carry out the operation. The information contained on the operation sheet includes the cutting speed, the feed rate, the depth of cut, the fixtures and the tools.

This system, seen as the integration of activities A12, A13 and A14, will have the part requirements for inputs and the various routing alternatives containing the tools and working conditions for the set of operations as its output (Fig. 7). The way the system functions will be controlled by the shape of the raw material, the knowledge, the operations and the databases; in other words, all the information

available about tools, machines, fixtures and orders, as well as the relationship among these variables, as can be seen in Figure 4.

[Caption figure 7]

The computer programme developed to generate and complete these formats is organised into the following stages: a) the general stage, where general data about the part, for example the part code, the lot, the number of the map, are presented; b) the main stage, where the bulk of the routing, for example the machine, the preparation cost and the operating cost, is entered; c) the operations, where the data from the operation sheets, for example number of the sub phase, the type of operation and the cutting conditions, are entered (Fig. 8); and d) the computational parameters, which provide the parameters of the cutting and the times and costs for the plain turning, milling, threading and drilling operations. Figure 8 shows the operation screen, where each table represents a sub phase. At the upper left margin there is a block of reference data where sub phases and operations can be added or eliminated. At the right there is a scroll feature for the planner to add and view as many sub phases as necessary.

[Caption figure 8]

## 5. Conclusions

This paper presents an activity model developed to summarise all the steps needed to plan a product from the design stage to the production order to the client delivery, without taking into consideration the assembly process. This is an extensive model encompassing two generally independent decision processes: planning productive processes and planning production.

Development of the activity model has led to some important goals. The following points highlight those goals.

1. A model has been developed to integrate the planning of productive processes and the production planning of these processes. This demonstrates how the integration of different systems is not only currently possible, but may even be essential in a not too distant future.
2. The developed IDEF activity model has established the framework, the relationships and the data required to compose the database resulting from the integration of data extensive fields like process and production domains. Process parameters like machine tools and fixtures, among others, have to be recorded. Likewise, production parameters such as the information related to distances between workshops, breakdowns, capacity and lay out must also be saved. Consequently, complete and consistent databases including all this information are needed. At present the same research group that has proposed the model is working on the design of a sound database to support the entire system.
3. The IDEF has proven to be a very valid tool for the development of these types of models, as well as for the continued improvement of the model presented. In fact, new system requirements (new variables, actions, etc.) have been easily included in the process without excessive remodelling of the previous model.
4. This model can be used as a basis for the computerized implementation of new planning support tools, as has been demonstrated in a brief example referring to decisions about operations, machines and tools.
5. It is difficult to develop a working methodology to develop these types of models that goes beyond meticulous group work by the members of the research group and an analysis of the planning process of various parts to produce.

The activity model has been developed in greater detail in the online version of this article (see Electronic Annex 1). As mentioned previously, the activity model has helped researchers develop computer systems for process and production planning with each activity having a different job as a goal.

At this stage, this work is being implemented in some of the companies which collaborate with the research group. First results are still not available, so it is not possible to analyse in detail the benefits obtained for the company with regard to financial and/or lead-time savings. However, it is clear that they exist.

In future work, after analysing the impact of the implementation of this model in real cases, activities which have not yet been developed must be. Likewise, new algorithms must be created to help integrate and create complete CAPP and PPC systems adapted to shop floor characteristics.

## 6. Acknowledgements

This work was carried out in the University of Girona by the Research group in Product, Process and Production Engineering (GREPP). The project was developed with the DPI2003 – 0561 reference grant awarded by the Spanish government.

## References

- [1] X. G. Ming, K. L. Mak and J. Q. Yan. A hybrid intelligent inference model for computer aided process planning, *Integrated Manufacturing Systems* **10** (1999) pp.343-353.
- [2] I. Ham and S. C. Y. Lu. Computer Aided Process Planning: the present and the future. *Annals of the CIRP* **37** (1988) (2), pp.591-601.
- [3] L. Alting and H. Zhang. Computer Aided Process Planning: the state-of-the art survey. *International Journal of Production Research* **27** (1989) pp.553-585.
- [4] T. S. Mujber, T. Szecsi and M. S. J. Hashmi. A new hybrid dynamic modelling approach for process planning, *Journal of Materials Processing Technology* **167** (2005/8/25) (1), pp.22-32.
- [5] C. Grabowik, K. Kalinowski and Z. Monica. Integration of the CAD/CAPP/PPC systems, *Journal of Materials Processing Technology* **164-165** (2005/5/15) pp.1358-1368.
- [6] L. H. Quiao, Z. B. Yang and B. Wang. A Computer-Aided Process Planning Methodology. *Computers in Industry* **25** (1994) (83),
- [7] M. A. Younis and M. A. Abdel Wahab. A CAPP expert system for rotational components. *Computers and Industrial Engineering* **33** (1997) pp.509-512.
- [8] Z. Gu, Y. F. Zhang and A. Y. C. Nee. Identification of important features for mahining operations sequence. *International Journal of Production Research* **35** (1997) (8), pp.2285-2307.
- [9] A. V. S. R. K. Prasad, P. N. Rao and U. R. K. Rao. Optimal Selection of process parameters for turning operations in a CAPP system. *International Journal of Production Research* **35** (1997) pp.1495-1522.
- [10] M. C. Kayacan and S. A. Çelik. Process planning system for prismatic parts. *Integrated Manufacturing Systems* **14** (2003) pp.75-86.
- [11] I. T. Kim and H. W. Suh. Optimal operation grouping and sequencing technique for multistage machining systems. *International Journal of Production Research* **36** (1998) (8), pp.2061-2081.
- [12] S. V. B. Reddy, M. S. Shunmugan and T. T. Narendran. Operation sequencing in CAPP using genetic algorithms. *International Journal of Production Research* **37** (1999) (5), pp.1067-1074.
- [13] L. Li, J. Y. H. Fuh, Y. F. Zhang and A. Y. C. Nee. Application of genetic algorithm to computer-aided process planning in distributed manufacturing environments, *Robotics and Computer-Integrated Manufacturing* **21** (2005/12) (6), pp.568-578.

- [14] M. Stevenson, L. C. Hendry and B. G. Kingsman. A review of production planning and control: the applicability of key concepts to the make-to-order industry *International Journal of Production Research* **43** (2005) (5), pp.869-898.
- [15] Chryssolouris, G. Chan, S. An Integrated Approach to Process Planning and Scheduling *CIRP Annals* **34** (1985) (1), pp.413-417.
- [16] R. M. Sundaram. Process Planning and Machining Sequence. *Computers and Industrial Engineering* **1986** **11** (1986) pp.184-188.
- [17] T. Hou and B. Wang. Integration of a CAPP system and an FMS, *Computers and Industrial Engineering* **20** (1991) (2), pp.231-242.
- [18] ElMaraghy, H.A. ElMaraghy, W.H. Bridging the gap between process planning and production planning and control, *Annals of the CIRP* **22** (1993) pp.1-10.
- [19] W. H. ElMaraghy. Integrating assembly planning and scheduling - CAPP related issues. *Annals of the CIRP* **41** (1992) (1), pp.11-14.
- [20] H. Steudel. Past, present and future the CAPP systems. *International Journal of Production Research* **1984**; **22** (2):253-66 **22** (1984) (2), pp.253-266.
- [21] R. Weill, G. Spur and W. Eversheim. Survey of Computer Aided Process Planning Systems, *Annals of the CIRP* **31** (1982) (2), pp.539-551.
- [22] Peihua Gu and D. H. Norrie. Intelligent manufacturing planning, **5** (1995) pp.342.
- [23] Gideon Halevi and Roland D. Weill. Principles of process planning : a logical approach, (1995) pp.399.
- [24] J. Ciurana, M. L. Garcia-Romeu, R. Castro and M. Alberti. A system based on machined volumes to reduce the number of route sheets in process planning, *Computers in Industry* **51** (2003/5) (1), pp.41-50.
- [25] S. A. Munawar and R. D. Gudi. Multilevel, Control-Theoretic Framework for Integration of Planning, Scheduling, and Rescheduling. *Ind. Eng. Chem. Res.* **44** (2005) pp.4001-4021.
- [26] T. Tsai and R. Sato. A UML model of agile production planning and control system. *Computers in Industry* **53** (2004) pp.133-152.
- [27] L. Howard and H. Lewis. The development of a database system to optimise manufacturing processes during design, *J.Mater.Process.Technol.* **134** (2003) (3), pp.374-382.
- [28] F. Gonzalez. Propuesta funcional y estructuración de información y conocimientos para la planificación de procesos asistida por computador. (1999)
- [29] A. Vidal, M. Alberti, J. Ciurana and M. Casadesus. A decision support system for optimising the selection of parameters when planning milling operations, *International Journal of Machine Tools and Manufacture* **45** (2005/2) (2), pp.201-210.
- [30] M. Alberti, J. Ciurana and M. Casadesus. A system for optimising cutting parameters when planning milling operations in high-speed machining, *Journal of Materials Processing Technology* **168** (2005/9/15) (1), pp.25-35.

# A MODEL FOR INTEGRATING PROCESS PLANNING AND PRODUCTION PLANNING AND CONTROL IN MACHINING PROCESSES

## Tables:

Table 1: Possible conditions of an operation to drill four holes and a single geometry

| Machine                   | Tool       | Fixture | Cost     | Time     | Observation |
|---------------------------|------------|---------|----------|----------|-------------|
| Four holes to be drilled  |            |         |          |          |             |
| Drill B-70                | Drill tool | A       | $C_{i1}$ | $T_{i1}$ |             |
| Drill B-50                | Drill tool | A       | $C_{i2}$ | $T_{i2}$ |             |
| Feixach (Mill)            | Drill tool | A       | $C_{i3}$ | $T_{i3}$ |             |
| CNC Millcenter            | Drill tool | A       | $C_{i4}$ | $T_{i4}$ |             |
| Isolated central geometry |            |         |          |          |             |
| Pinacchio Lathe           | Cylinder   | B       | $C_{k1}$ | $T_{k1}$ |             |
| CNC Lathe                 | Cylinder   | B       | $C_{k2}$ | $T_{k2}$ |             |
| Feixach (Mill)            | Mill tool  | A       | $C_{k3}$ | $T_{k3}$ |             |
| CNC Millcenter            | Mill tool  | A       | $C_{k4}$ | $T_{k4}$ |             |

Table 2: Relations between actions and information

| Action  | Input  | Output   | Information as control or resource   |
|---|--|--|--|
| Raw material  | Draw part  | Preform  | External size of drawing<br>Order of parts needed  |
| Volume approximation                                    | Draw part  | Volumes to machine                                       | Dimensional and geometrical requirements   |
| Volume accuracy   | Preform  | Finished volumes   | Dimensional and geometrical requirements<br>Roughness  |
| Geometric volume  | Preform  | Characterize the geometry and tolerances                 | Geometrical requirements   |
| Determine options to operations in machines             | Draw part  | Options and operations<br>Error or incapacity            | Operations<br>Machine tool database<br>Tool database<br>Fixture database                       |
| Sequence operations in machines                         | Draw part<br>Options and operations                                  | Sequences and operations<br>Error or incapacity<br>Shape | Cost and time operations<br>Shop floor database<br>Historical data of waiting and set-up times |
| Dissagregate route sheet for work shops                 | Route sheets   | Operation / Machine Centers                              | Cost and time sequences  |
| Generate alternatives & Evaluate capacity of work shops | Operation / Machine Centers  | Possible rout sheets<br>Disponibility                    | Shop floor capacity<br>Breakdowns<br>Machines database   |
| Sequence processes & Generate production plann          | Operation / Machine Centers<br>Possible route sheets<br>Cost<br>Time | Route<br>Production Plan                                 | Shop floor capacity  |

# A MODEL FOR INTEGRATING PROCESS PLANNING AND PRODUCTION PLANNING AND CONTROL IN MACHINING PROCESSES

Figures:

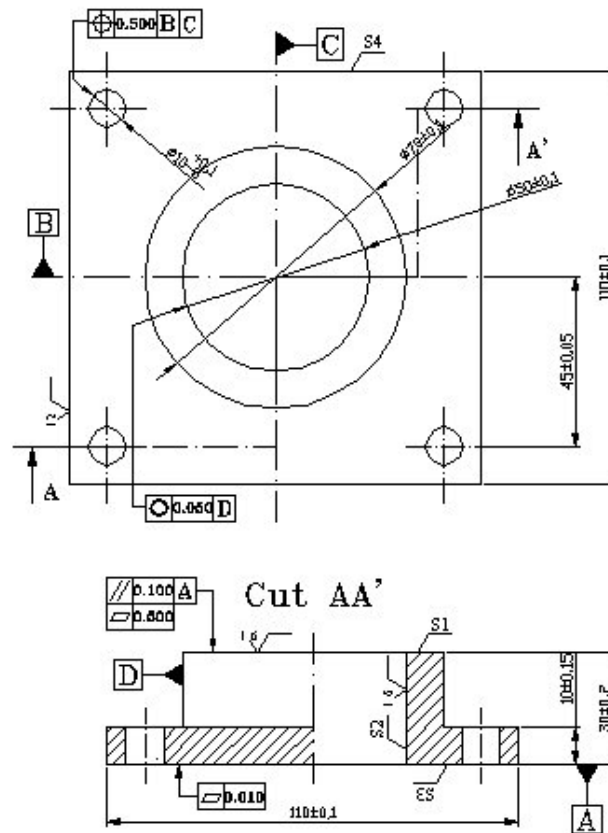

Figure 1: Example of a drawn part

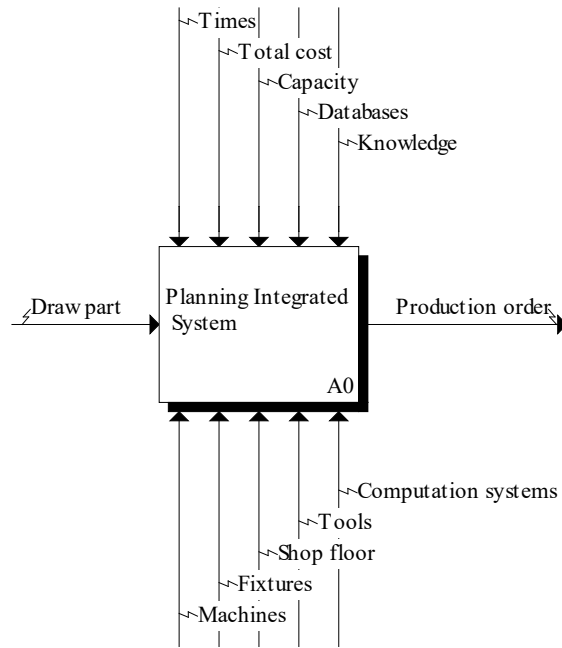

Figure 2: Initial level of the IDEF model

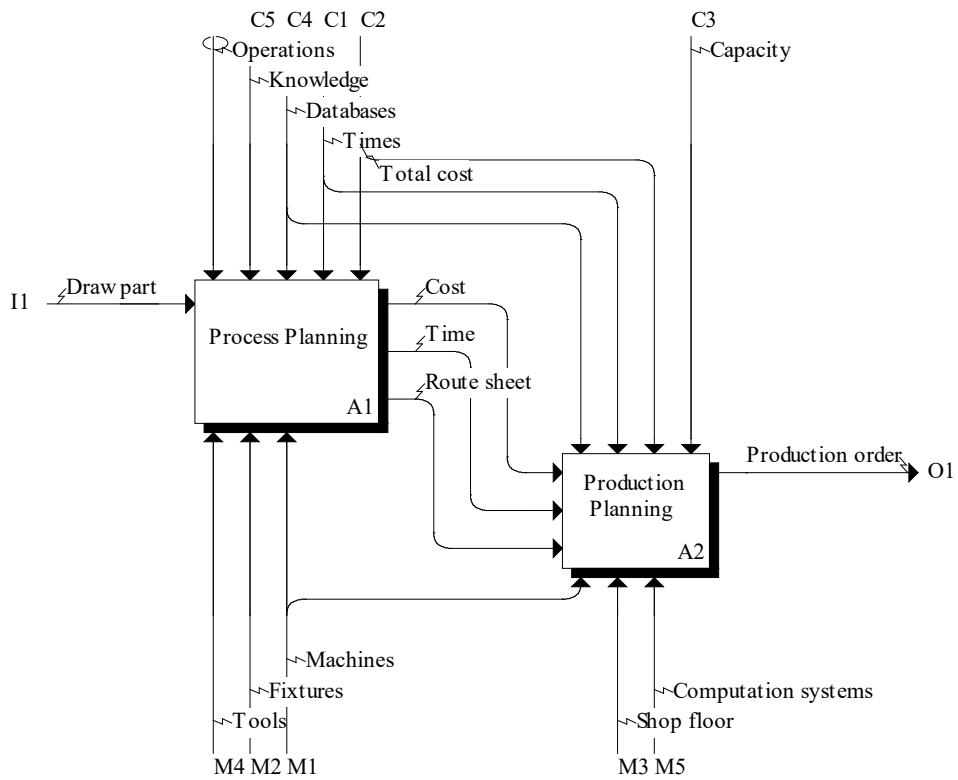

Figure 3: First level of the IDEF model

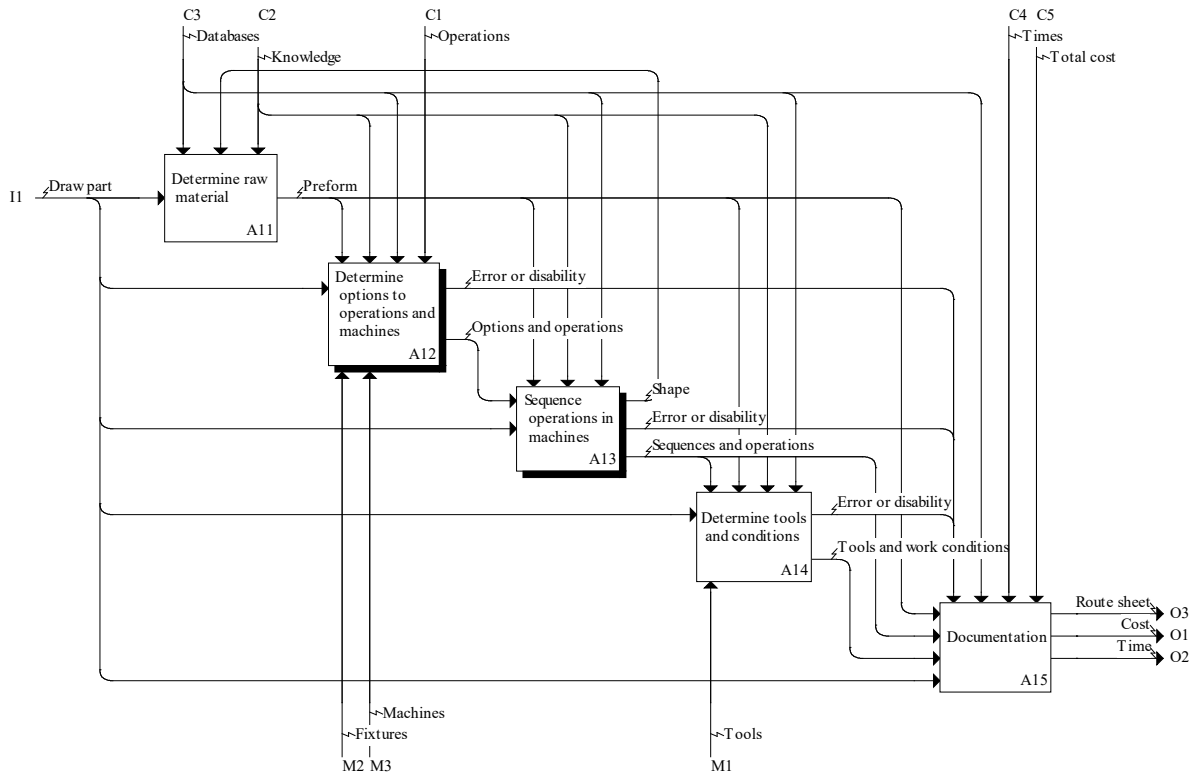

Figure 4: Process planning level in the IDEF model

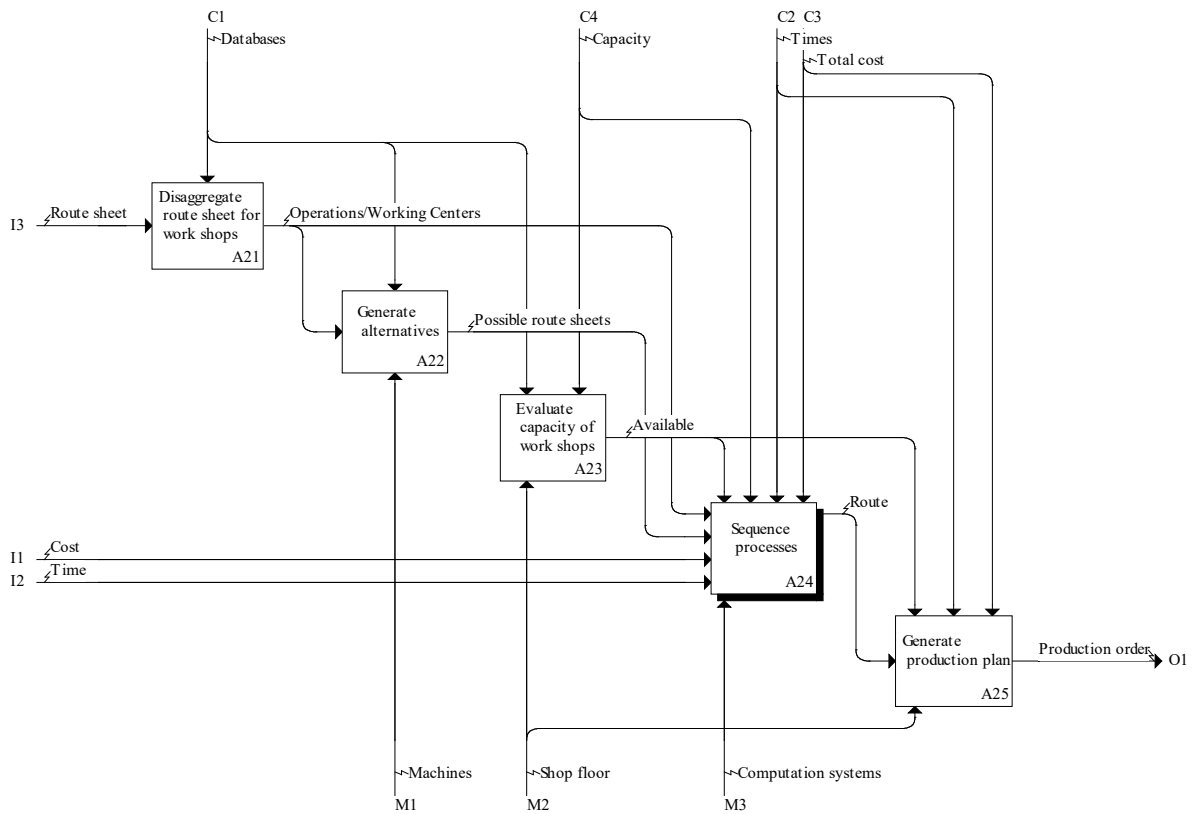

Figure 5: Production planning level in the IDEF model



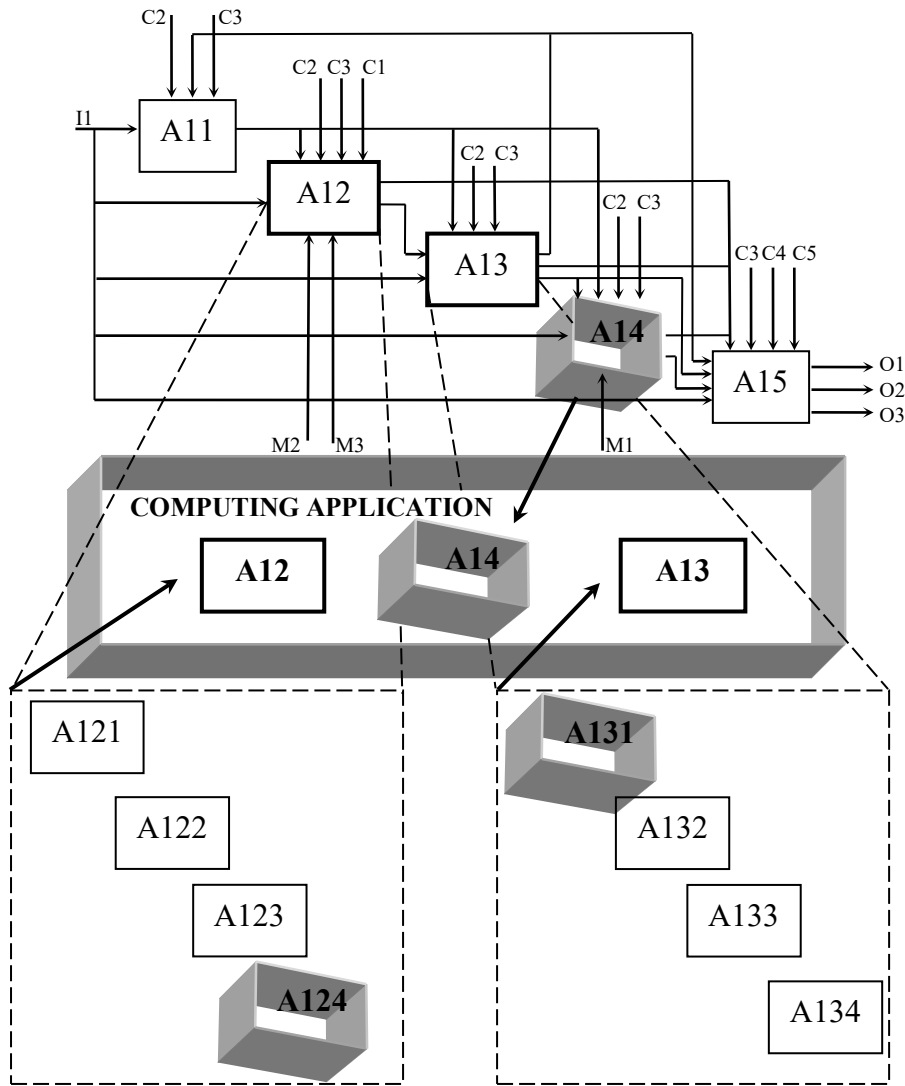

Figure 6: Implemented application

## Routing Sheet

|                         |                       |                 |            |
|-------------------------|-----------------------|-----------------|------------|
| Part code               | 1982                  | Option          | 1          |
| Name                    | Centring tool stand   |                 |            |
| Part drawing            | 3                     | Customer        | UdG        |
| Material                | aluminium             | Lot             | 100        |
| Raw material dimensions | diameter 86 x 32 (mm) | Inspection date | 20/07/2005 |

| phase number | machine  | description                       | t <sub>prep</sub> (min) | t <sub>cicle</sub> (min) | Cost prep (€) | Cost cicle(€) |
|--------------|----------|-----------------------------------|-------------------------|--------------------------|---------------|---------------|
| 1            | CN lathe | machining of cylindrical surfaces | 115                     | 200                      | 43            | 543           |
| 2            | drill    | lateral drill holes               | 226                     | 150                      | 67            | 262           |

3 CM1

### Operation sheet

|              |                     |          |
|--------------|---------------------|----------|
| Part code    | 1982                | Option 1 |
| Name         | Centring tool stand |          |
| Part drawing | 3                   |          |

4 threading t

|             |                     |
|-------------|---------------------|
| Phase no.   | 2                   |
| Machine     | drill               |
| Description | lateral drill holes |

Sub phase no. 2.1

Programme no. 56

| Oper. no. | Type     | Description       | Tool code | Fixture     | N (rpm) | Vc (m/min) | L/NI (mm) / | feed rate (mm/rev) | depth of cut (mm) | pass no. | t <sub>unproductive</sub> (min) | t <sub>cut</sub> (min) | t <sub>prep</sub> (min) | t <sub>ch-to/T</sub> (min) | Ce-tc/T (€) |
|-----------|----------|-------------------|-----------|-------------|---------|------------|-------------|--------------------|-------------------|----------|---------------------------------|------------------------|-------------------------|----------------------------|-------------|
| 2.1.1     | drilling | 1 hole diam. 4    | 354       | clamp plate | 500     | 100        | 6           | 0,5                | 0,5               | 1        | 54                              | 433534                 |                         | 45                         | 354         |
|           |          |                   |           |             |         |            |             | 0,15               | 0,5               | 1        |                                 |                        |                         |                            |             |
|           |          |                   |           |             |         |            |             | 0,501              | 0,4               | 1        |                                 |                        |                         |                            |             |
|           |          |                   |           |             |         |            |             | 1,5                | 0,4               | 1        |                                 |                        |                         |                            |             |
| 2.1.2     | drilling | 6 holes diam. 8mm | 5463      |             | 600     | 100        | 13          | 0,46               | 0,8               | 1        | 51                              | 846                    |                         | 5435                       | 534         |
|           |          |                   |           |             |         |            |             | 0,45               | 0,51              | 1        |                                 |                        |                         |                            |             |
|           |          |                   |           |             |         |            |             | 0,56               | 0,4               | 1        |                                 |                        |                         |                            |             |
|           |          |                   |           |             |         |            |             | 0,54               | 0,52              | 1        |                                 |                        |                         |                            |             |
| 2.1.3     | drilling | 2 holes diam. 6   | 43        | flange      | 580     | 150        | 10          | 0,453              | 0,35              | 1        | 21                              | 354354                 | 4                       | 534                        | 54          |
|           |          |                   |           |             |         |            |             | 0,254              | 0,5               | 1        |                                 |                        |                         |                            |             |
|           |          |                   |           |             |         |            |             | 0,548              | 0,54              | 1        |                                 |                        |                         |                            |             |
|           |          |                   |           |             |         |            |             | 0,4                | 0,2               | 1        |                                 |                        |                         |                            |             |

Figure 7: Samples of routings and operation sheets

**Operations**

Part code: 31    option: 6

Name: Closing column lower stand

Page: 3

Machine: CM1

Raw material: diameter 86 x 32 (mm)

Phase: 1

Operation name: [dropdown]

Description: [text box]

Use: [text box]

Tool code: [text box]

operation update

Phase screen    user manual

operations

Sub phase x

Sub phase

Sub phase

Sub phase: 1.1

| n° op | Operation         | Description        | Tool | Fixture | N (rpm)  | Feed rate    | Depth of cut | Pass no |
|-------|-------------------|--------------------|------|---------|----------|--------------|--------------|---------|
| 1.1.1 | tangential mil... | face 80 x 130 mm^2 | 123  | flange  | 954,9274 | 0,5/2,12/0/0 | 2,1/0,4/0/0  | 1/1/0/0 |
|       |                   |                    |      |         |          |              |              |         |
|       |                   |                    |      |         |          |              |              |         |
|       |                   |                    |      |         |          |              |              |         |

Programme no. 111

Subfase: 1.2

| n° op | Operation         | Description              | Tool | Fixture | N (rpm)  | Feed rate    | Depth of cut | Pass no |
|-------|-------------------|--------------------------|------|---------|----------|--------------|--------------|---------|
| 1.2.1 | tangential mil... | other face 80 x 130 m... | 123  | flange  | 954,9274 | 0,5/2,12/0/0 | 2,1/0,4/0/0  | 1/1/0/0 |
| 1.2.2 | frontal milling   | circular pocket          | 123  | flange  | 760      | 0,1/0,1/0/0  | 1/1/0/0      | 1/1/0/0 |
|       |                   |                          |      |         |          |              |              |         |
|       |                   |                          |      |         |          |              |              |         |

N° programa 111

Figure 8: Operations screen with one input operation for sub phase 1.1 and two operations for sub phase 1.2