

Treball final de grau

Estudi: Grau en Enginyeria Mecànica

Títol: Escalfador d'aigua per efecte Foucault

Document: Plànols

Alumne: Sergi Camps Torrell

Tutor: Lino Montoro Moreno

Departament: Enginyeria mecànica i de la construcció Industrial

Àrea: Màquines i Motors Tèrmics

Convocatòria (mes/any) (01/2020)

ÍNDEX

PLÀNOLS

| | |
|--|----|
| 1. VGP, VISTA GENERAL DE LA PEÇA | 2 |
| 2. EX, EXPLOSIONAT | 3 |
| 3. TG, TALL GENERAL..... | 4 |
| 4. ROT, ROTOR | 5 |
| 5. TF, TAPA FRONTAL | 6 |
| 6. TS, TAPA SUPERIOR..... | 7 |
| 7. TI, TAPA INFERIOR..... | 8 |
| 8. XS, XAPA SUPORT | 9 |
| 9. SBK, SILENTBLOCK..... | 10 |



Tolerancias generales de fabricacion

| | | | | | |
|------------|--|------|--------|---------|----------|
| Medida | | 6-30 | 30-120 | 120-315 | 315-1000 |
| Tolerancia | | | | | |

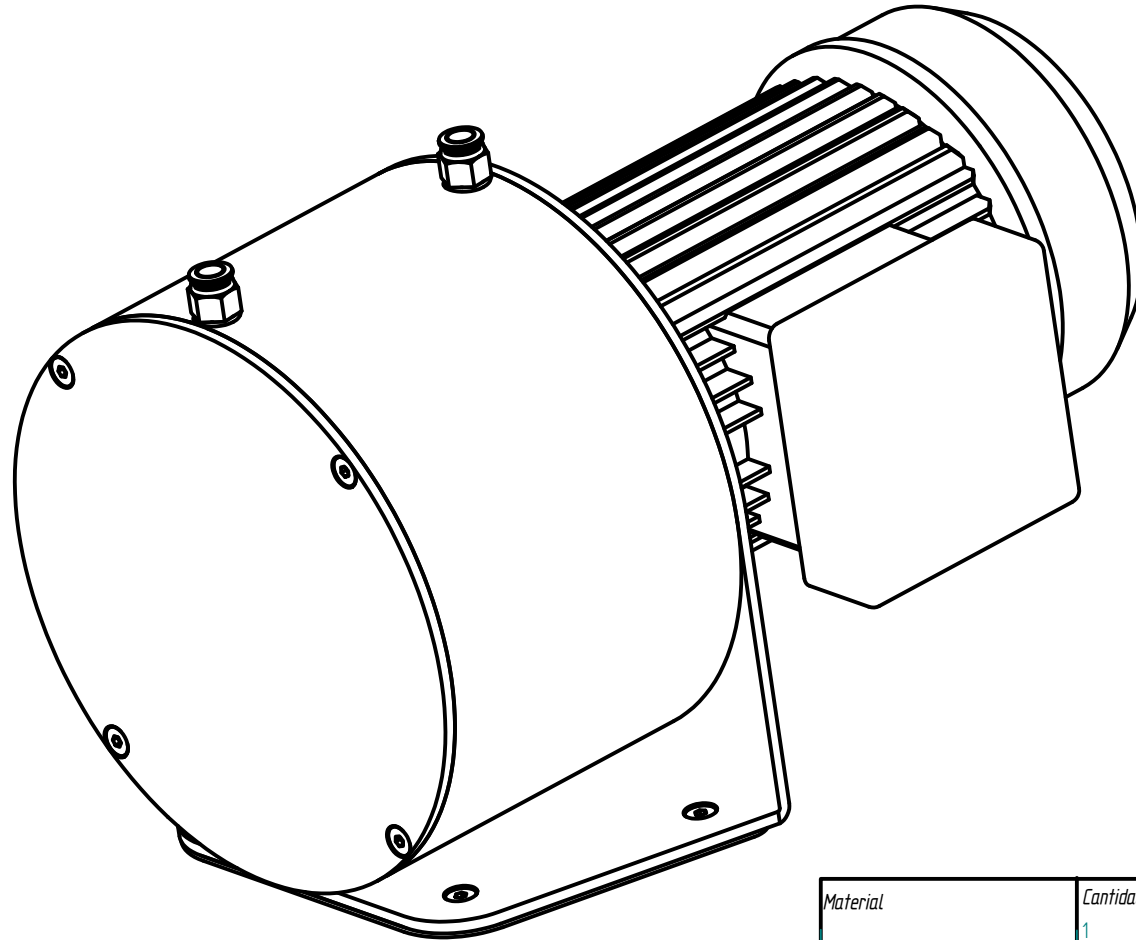

| | | | | |
|---|---------------------|-------------------------|--|---------------------------------|
| Material | Cantidad 1 | Escala | | Escola politècnica Superior |
| Tratamiento | Fecha 18/12/2019 | Dibujado Sergi Camps | | |
| Modificado | Nombre | Fecha | | |
| Designacion pieza VGP VISTA GENERAL CALENTADOR | | Pedido | Nº Plano VGP-VISTA GENERAL CALENTADOR.dft | Conjunto |

| Tolerancias generales de fabricacion | | | | | |
|--------------------------------------|--|------|--------|---------|----------|
| Medida | | 6-30 | 30-120 | 120-315 | 315-1000 |
| Tolerancia | | | | | |

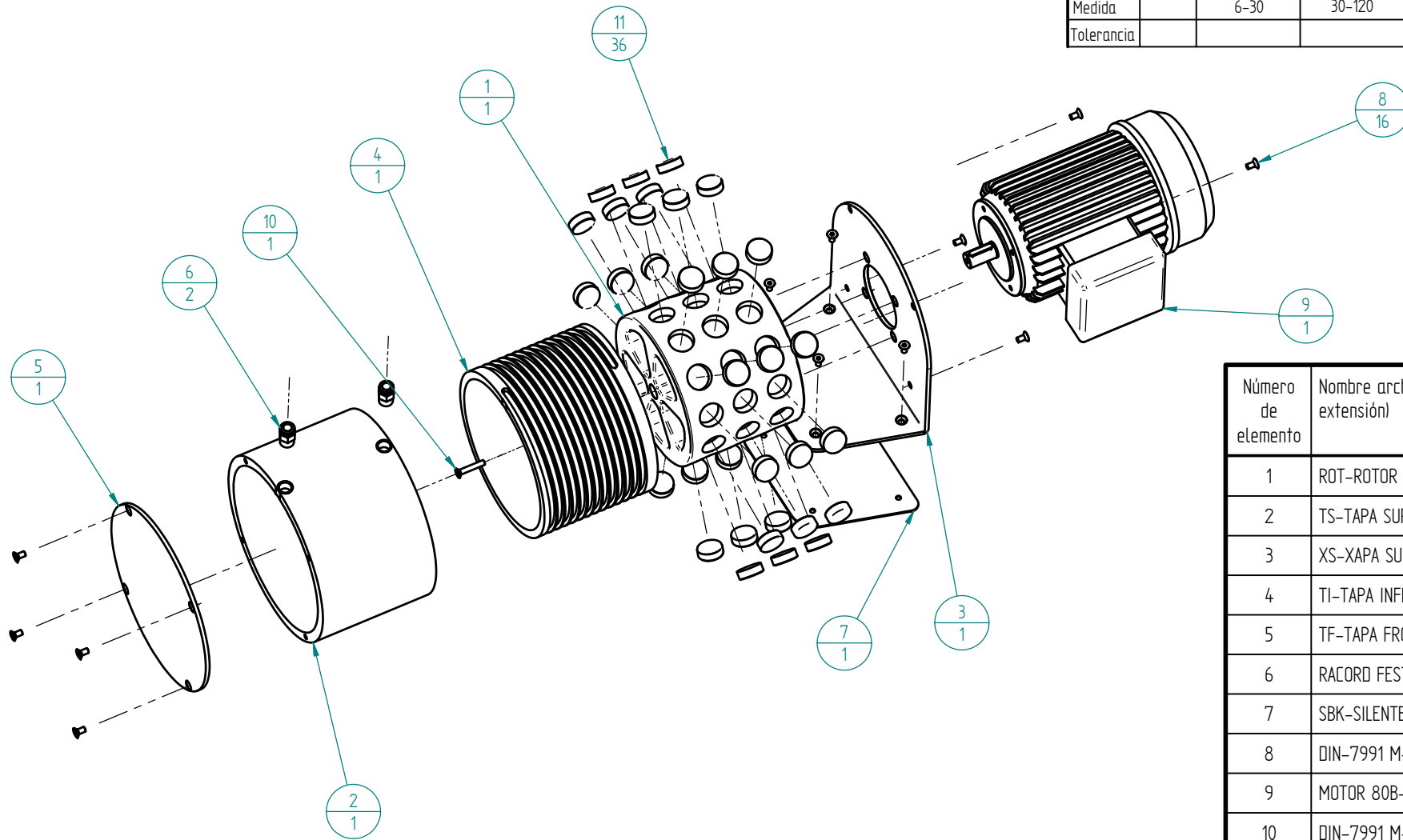

| Número de elemento | Nombre archivo (sin extensión) | Cantidad |
|--------------------|--------------------------------|----------|
| 1 | ROT-ROTOR | 1 |
| 2 | TS-TAPA SUPERIOR | 1 |
| 3 | XS-XAPA SUPORT | 1 |
| 4 | TI-TAPA INFERIOR | 1 |
| 5 | TF-TAPA FRONTAL | 1 |
| 6 | RACORD FESTO QS-10 3/8 | 2 |
| 7 | SBK-SILENTBLOCK | 1 |
| 8 | DIN-7991 M-6x12 | 16 |
| 9 | MOTOR 80B-400V-B14-1,1Kw | 1 |
| 10 | DIN-7991 M-6x35 | 1 |
| 11 | IMANT NEODIMI Ø30x10 | 36 |

| | | | | |
|-------------------|---------------------|-------------------------|-----------------------------|---------------------------------|
| Material | Cantidad | Escala | | Escola politècnica Superior |
| Tratamiento | Fecha 05/01/2020 | Dibujado Sergi Camps | | |
| Modificado | Nombre | Fecha | | |
| Designacion pieza | | Pedido | Nº Plano EX-EXPLOSIONAT.dft | |
| | | | Conjunto | |

| Tolerancias generales de fabricacion | | | | | |
|--------------------------------------|--|------|--------|---------|----------|
| Medida | | 6-30 | 30-120 | 120-315 | 315-1000 |
| Tolerancia | | | | | |

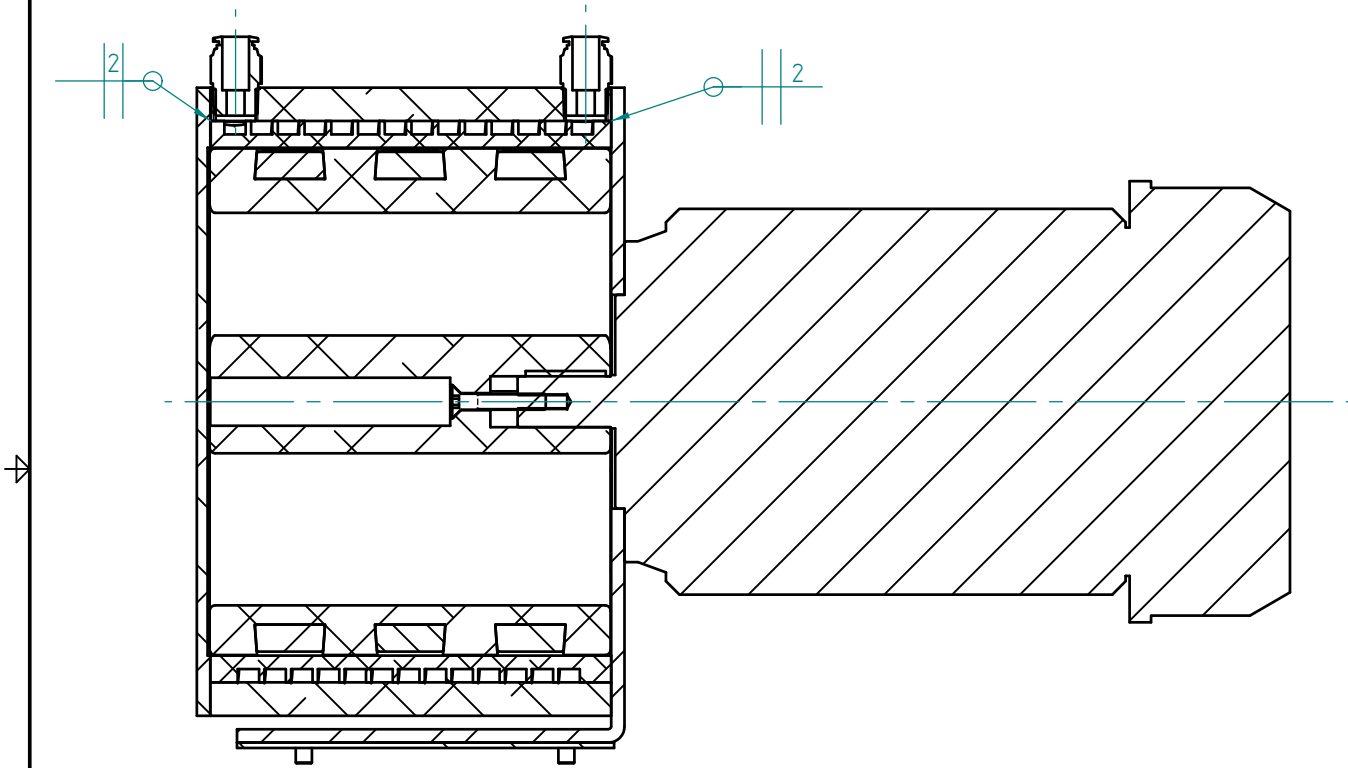

CORTE A-A

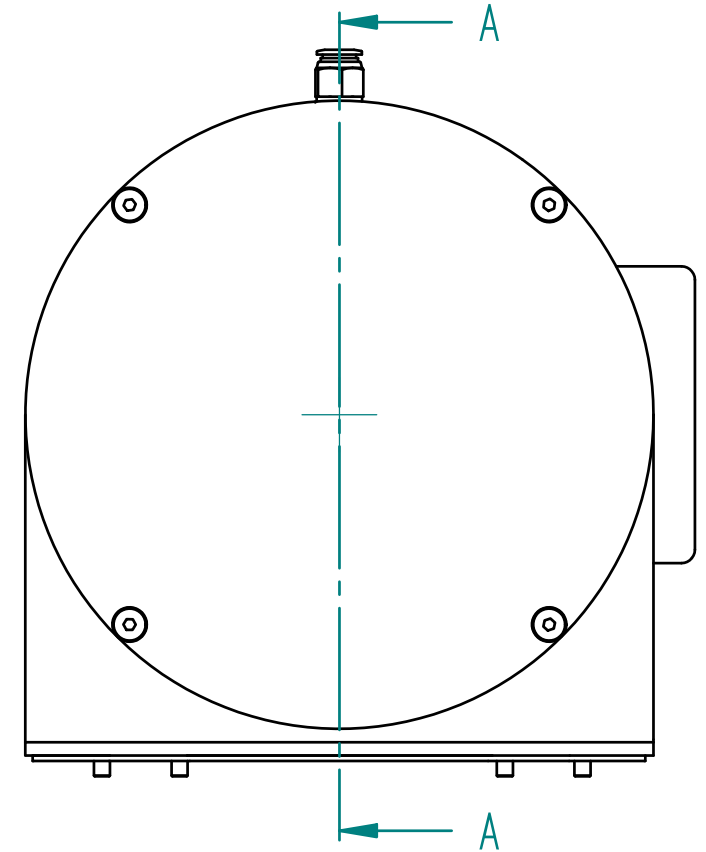

| | | | | |
|-------------------|---------------------|----------|-------------|---------------------------------|
| Material | Cantidad 1 | Escala | | Escola politècnica Superior |
| Tratamiento | Fecha 18/12/2019 | Dibujado | Sergi Camps | |
| Modificado | Nombre | Fecha | | |
| Designacion pieza | TG- TALL GENERAL | | Pedido | Nº Plano 1 TG- TALL GENERAL.dft |
| | | | | Conjunto |

| Tolerancias generales de fabricacion | | | | | |
|--------------------------------------|--|------|--------|---------|----------|
| Medida | | 6-30 | 30-120 | 120-315 | 315-1000 |
| Tolerancia | | | | | |

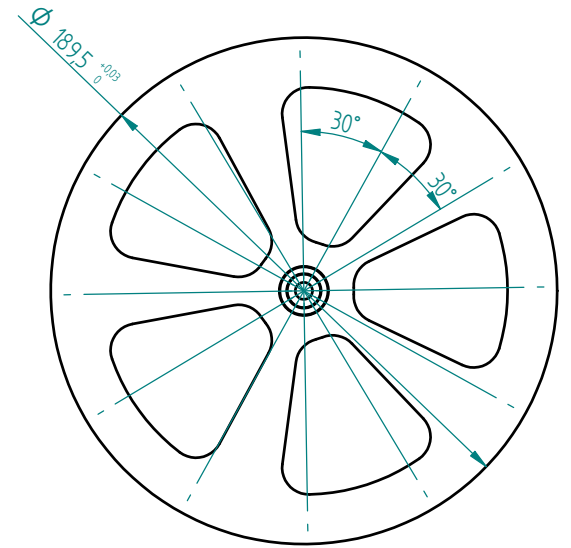
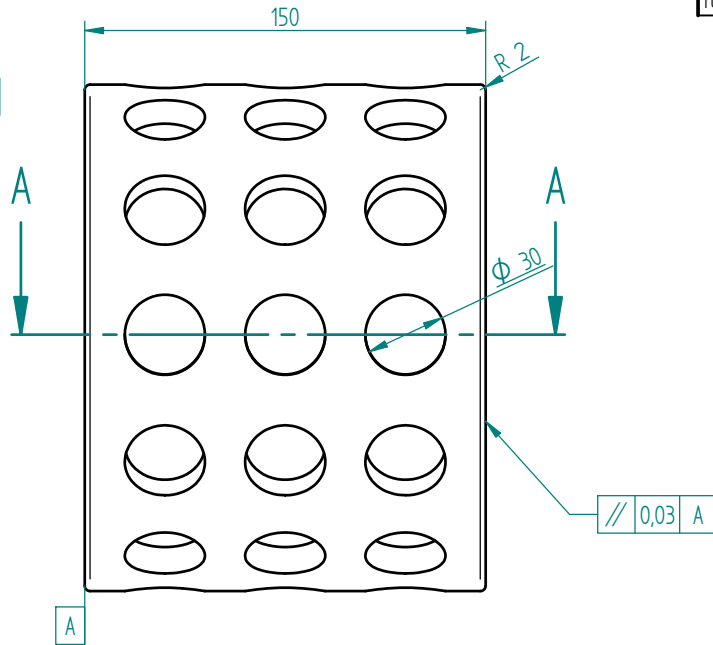
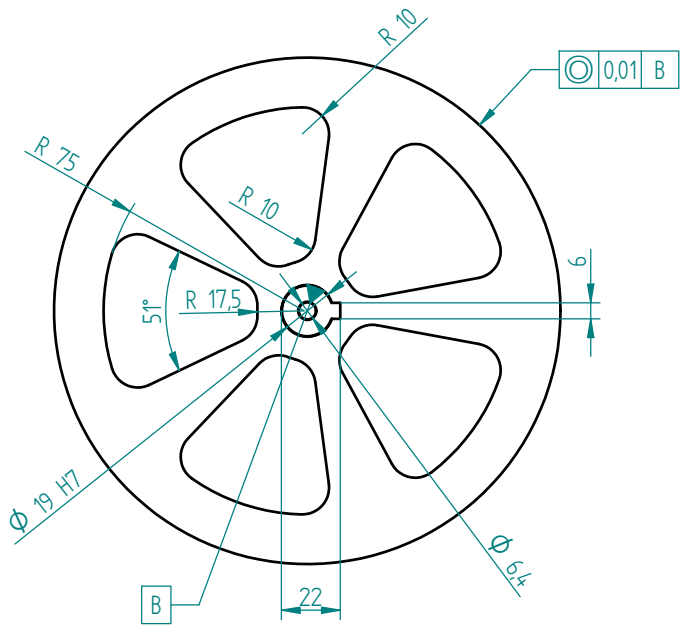

CORTE A-A

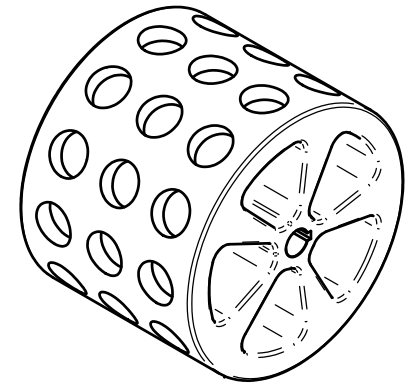
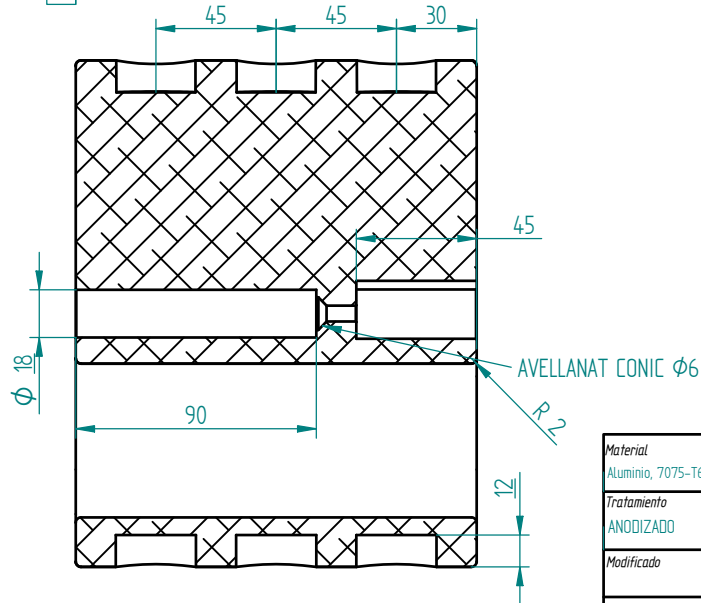

| | | | |
|---------------------------------|---------------------|---------------------------|---------------------------------|
| Material Aluminio, 7075-T6 | Cantidad 1 | Escala | Escola politècnica Superior |
| Tratamiento ANODIZADO | Fecha 18/12/2019 | Dibujado Sergi Camps | |
| Modificado | Nombre | Fecha | |
| Designacion pieza ROT- ROTOR | Pedido | Nº Plano ROT-ROTOR.dft | Conjunto |

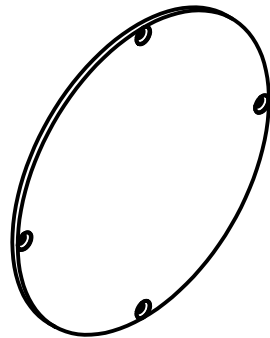
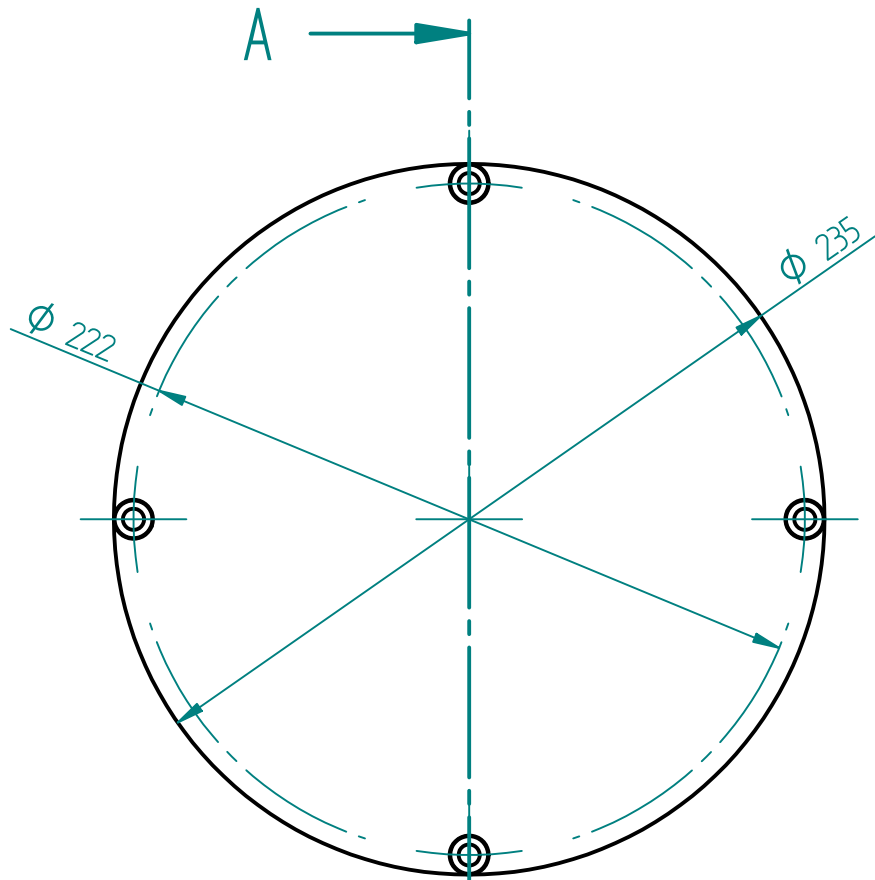

| Tolerancias generales de fabricacion | | | | | |
|--------------------------------------|--|------|--------|---------|----------|
| Medida | | 6-30 | 30-120 | 120-315 | 315-1000 |
| Tolerancia | | | | | |

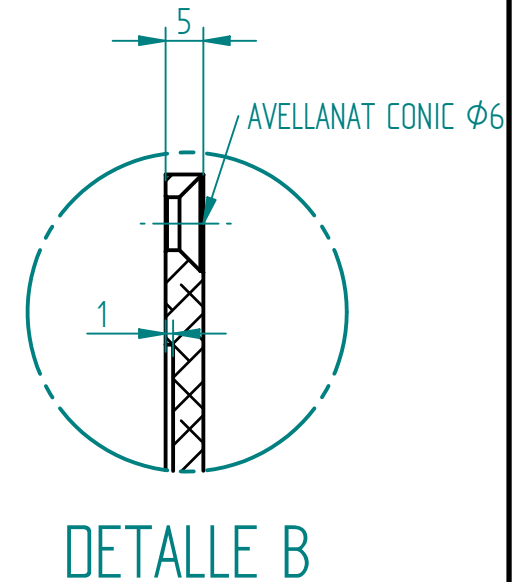
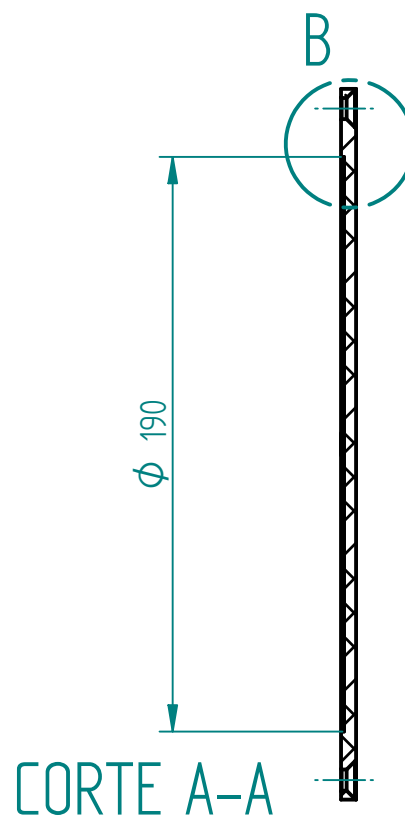

| | | | | |
|---------------------------------------|---------------------|-------------------------|---------------------------------|---------------------------------|
| Material Aluminio, 7075-T6 | Cantidad 1 | Escala 1/1 | | Escola politècnica Superior |
| Tratamiento ANODITZAT | Fecha 19/12/2019 | Dibujado Sergi Camps | | |
| Modificado | Nombre | Fecha | | |
| Designacion pieza TF- TAPA FRONTAL | | Pedido | Nº Plano TF-TAPA FRONTAL.dft | Conjunto |

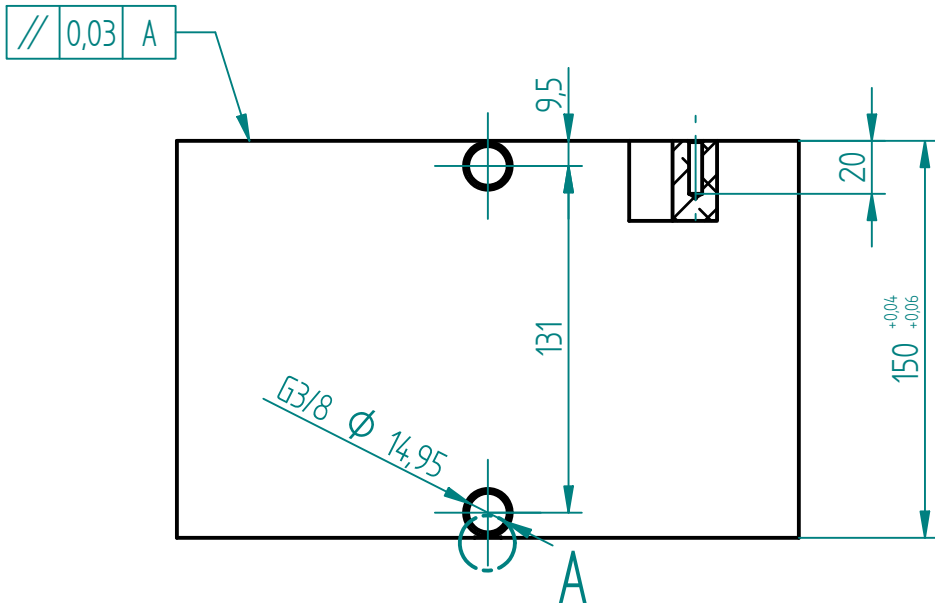
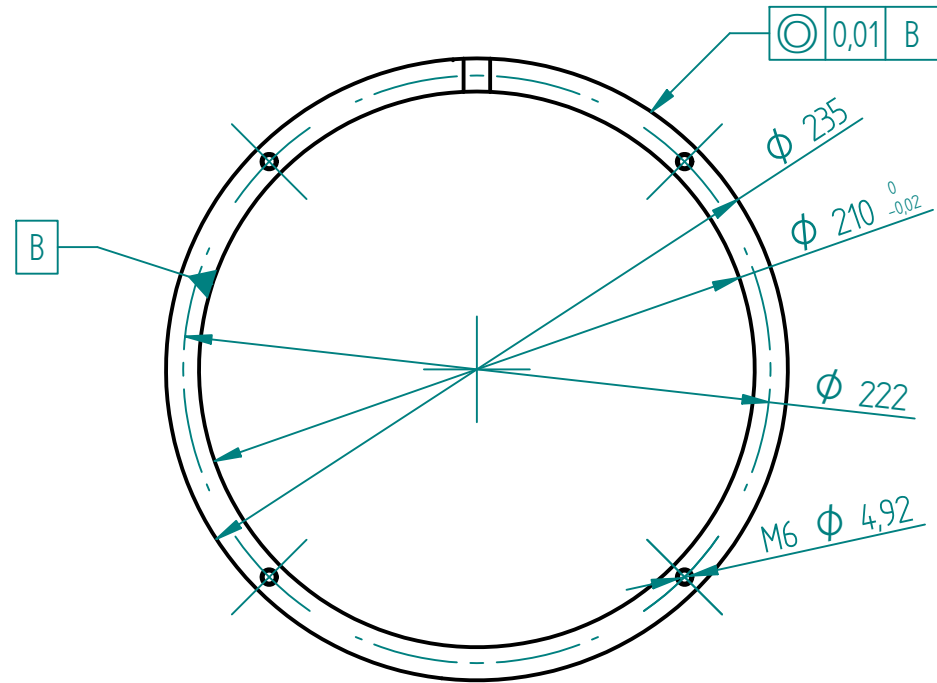

Tolerancias generales de fabricacion

| Medida | 6-30 | 30-120 | 120-315 | 315-1000 |
|------------|------|--------|---------|----------|
| Tolerancia | | | | |

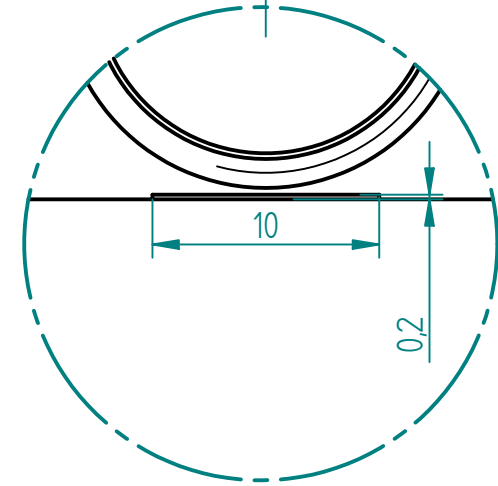

DETALLE A

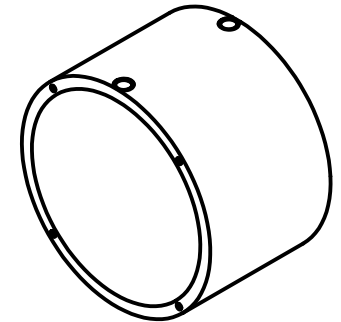

| | | | | |
|--|---------------------|----------------------------------|--|--|
| Material Aluminio, 7075-T6 | Cantidad 1 | Escala | | |
| Tratamiento ANODIZADO | Fecha 22/11/2019 | Dibujado Sergi Camps | | |
| Modificado | Nombre | Fecha | | |
| Designacion pieza TS- TAPA SUPERIOR | Pedido | Nº Plano TS-TAPA SUPERIOR.dft | | |
| | | Conjunto | | |

| Tolerancias generales de fabricacion | | | | | |
|--------------------------------------|--|------|--------|---------|----------|
| Medida | | 6-30 | 30-120 | 120-315 | 315-1000 |
| Tolerancia | | | | | |

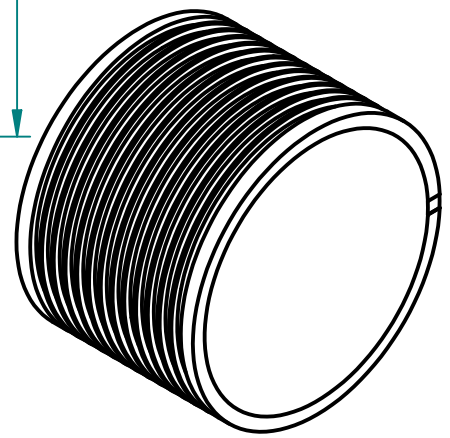
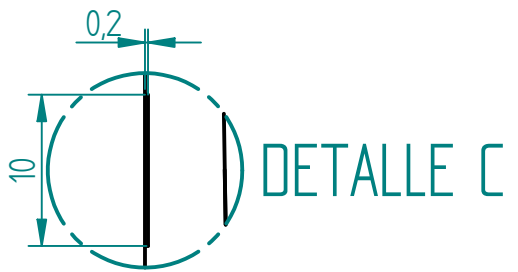
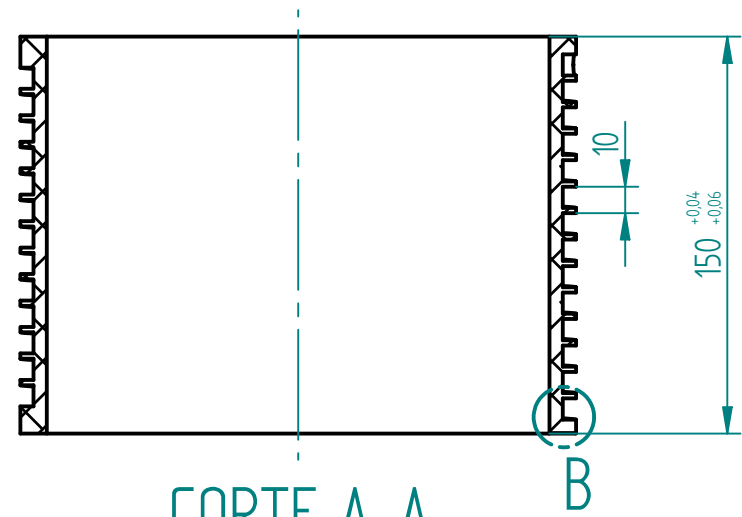
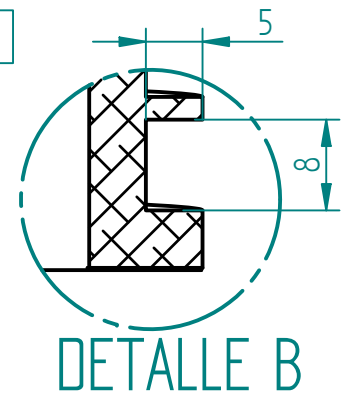
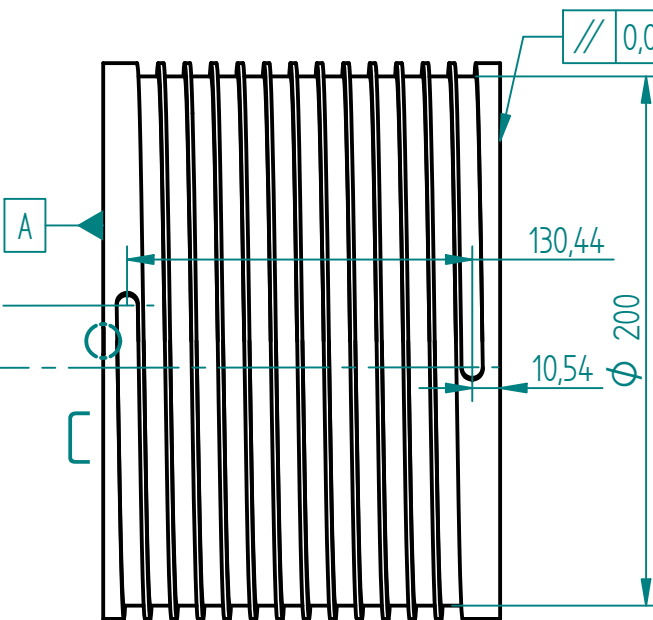
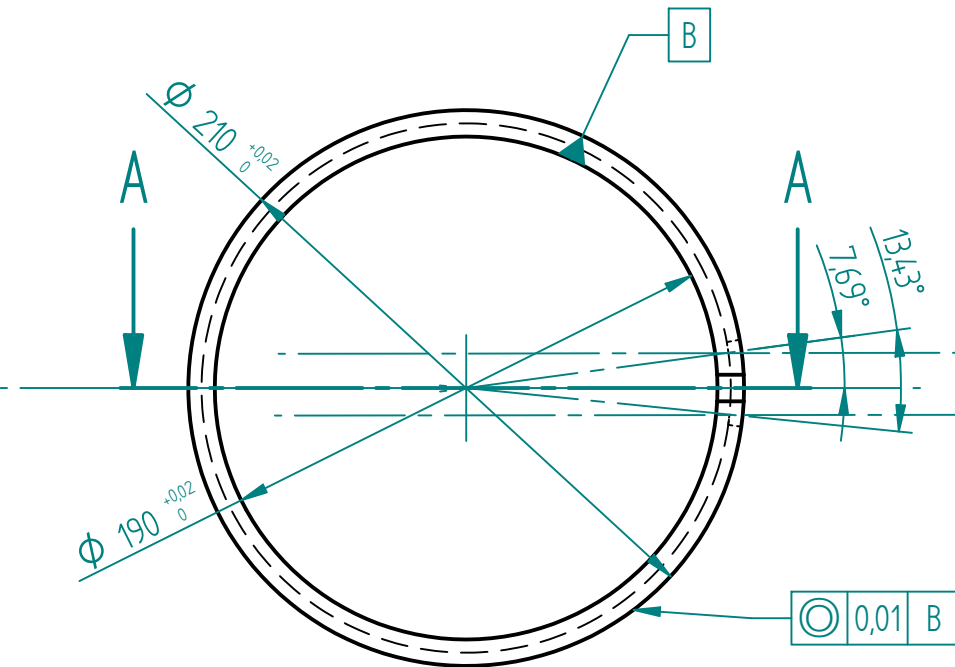

| | | | | |
|---------------------------------------|---------------------|----------------------------------|--|---------------------------------|
| Material Aluminio, 7075-T6 | Cantidad 1 | Escala | | Escola politècnica Superior |
| Tratamiento ANODIZADO | Fecha 22/11/2019 | Dibujado Sergi Camps | | |
| Modificado | Nombre | Fecha | | |
| Designacion pieza TI-TAPA INFERIOR | Pedido | Nº Plano TI-TAPA INFERIOR.dft | | Conjunto |

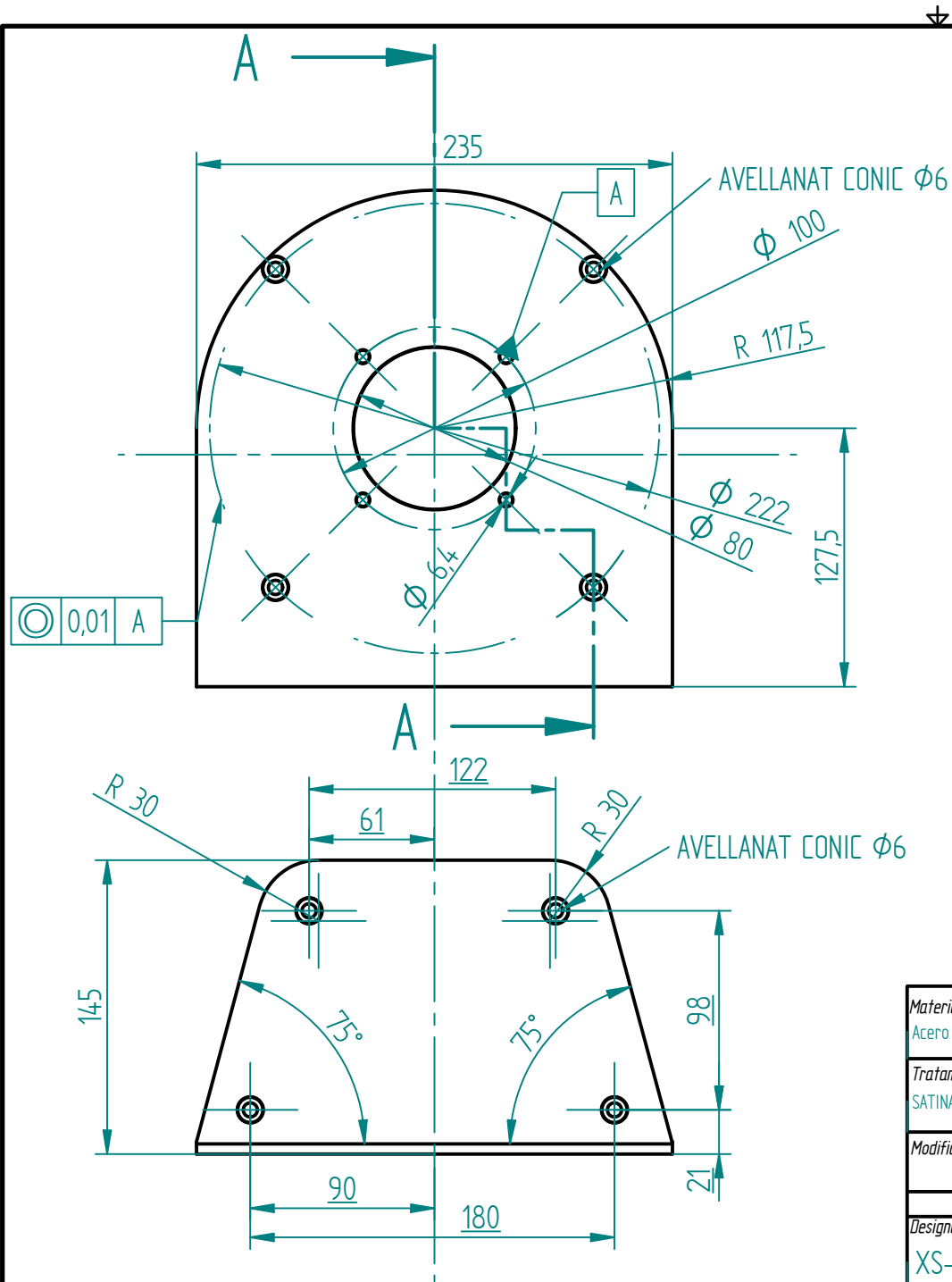

| Tolerancias generales de fabricacion | | | | | |
|--------------------------------------|--|------|--------|---------|----------|
| Medida | | 6-30 | 30-120 | 120-315 | 315-1000 |
| Tolerancia | | | | | |

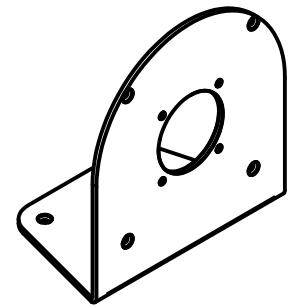
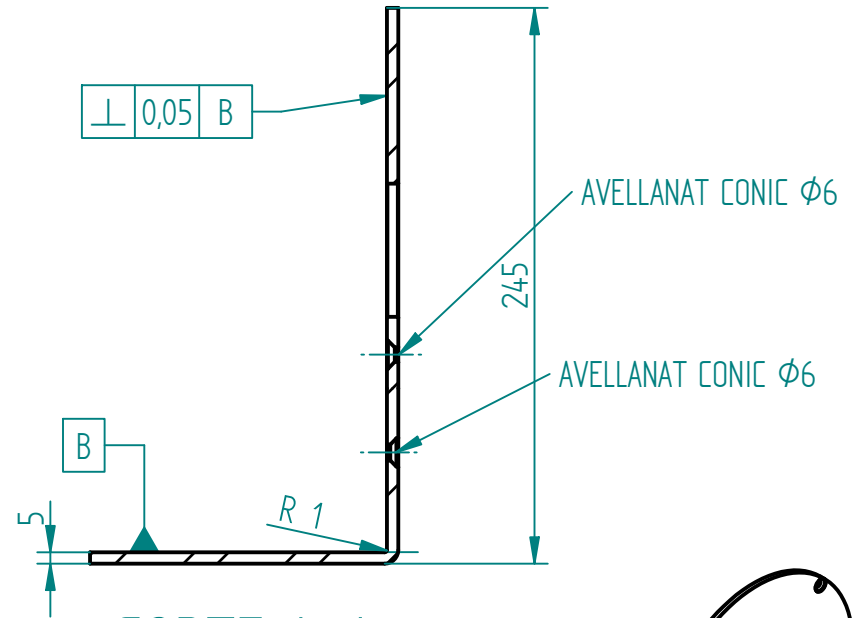

| | | | | |
|--------------------------------------|---------------------|-----------------------------|--|---------------------------------|
| Material Acero inoxidable, 304 | Cantidad 1 | Escala | | Escola politècnica Superior |
| Tratamiento SATINAT | Fecha 18/12/2019 | Dibujado Sergi Camps | | |
| Modificado | Nombre | Fecha | | |
| Designacion pieza XS- XAPA SUPORT | Pedido | Nº Plano XS-XAPA SUPORT.dft | | |
| | | Conjunto | | |

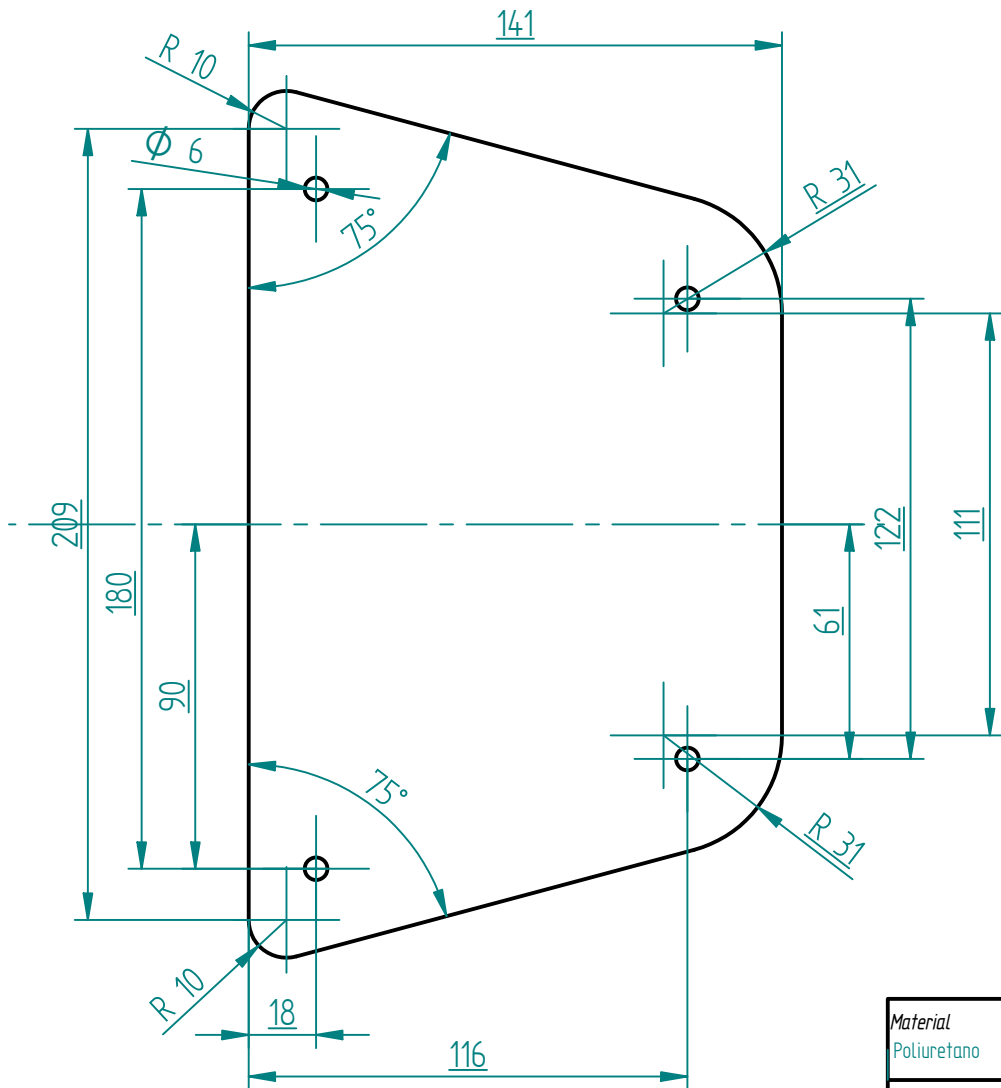

Tolerancias generales de fabricacion

| | | | | | |
|------------|--|------|--------|---------|----------|
| Medida | | 6-30 | 30-120 | 120-315 | 315-1000 |
| Tolerancia | | | | | |

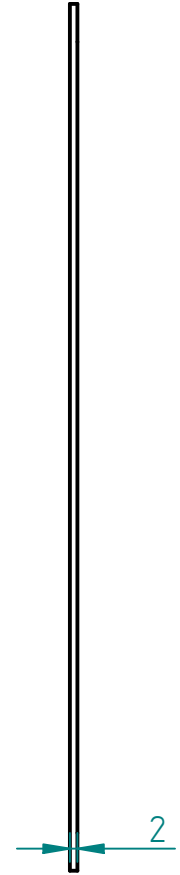

| | | | | |
|---------------------------------------|---------------------|-------------------------|---------------------------------|----------|
| Material Poliuretano | Cantidad 1 | Escala | | |
| Tratamiento | Fecha 20/12/2019 | Dibujado Sergi Camps | | |
| Modificado | Nombre | Fecha | | |
| Designacion pieza SBK- SILENTBLOCK | | Pedido | Nº Plano SBK-SILENTBLOCK.dft | Conjunto |