

Treball final de grau

Estudi: Grau en Enginyeria Mecànica

Títol:

**Disseny i desenvolupament d'una premsa per
assistir en la soldadura de tubs d'escapament de
motos de trial.**

Document 2: Plànols

Alumne: Arnau Jovanet Argelés

Tutor: Inés Ferrer Real

Departament: Enginyeria mecànica i de la construcció
industrial

Àrea: Enginyeria dels processos de fabricació

Convocatòria (mes/any): 06/2022



ÍNDIX DE CONTINGUTS

II. Plànols	3
0.00 Conjunt GENERAL PREMSA HIDRÀULICA.....	4
1.00 i 1.00_1 Conjunt ESTRUCTURA PREMSA.....	5 i 6
1.01 UPN 140x900 INFERIORS.....	7
1.02 UPN 140x900 CENTRALS	8
1.03 UPN 140x900 SUPERIORS.....	9
1.04 UPN 140x180.....	10
1.05 Centrador pistó hidràulic	11
1.06 Suport grup hidràulic.....	12
1.07 Suport grup hidràulic curt	13
1.08 Gruix tirants.....	14
1.09 Tirants bancada	15
1.10 Placa embellidora superior	16
2.00 Conjunt RODAMENT	17
2.01 Base rodament inferior	18
2.02 Base rodament superior.....	19
3.00 Conjunt PISTÓ HIDRÀULIC	20
3.01 Unió pistó-rodament.....	21
4.00 Conjunt MATRIU PORTAMOTLLOS.....	22
4.01 Placa SUPERIOR matriu portamotllos	23
4.02 i 4.03 Placa INFERIOR matriu portamotllos.....	24 i 25
4.04 Tope mecànic D40.....	26
4.05 Tope mecànic D42.....	27
4.06 Suport 1 centrador casquillo	28
4.07 Suport 2 centrador casquillo	29
4.08 Centrador casquillo	30
4.09 Casquillo centrador boquilla	31

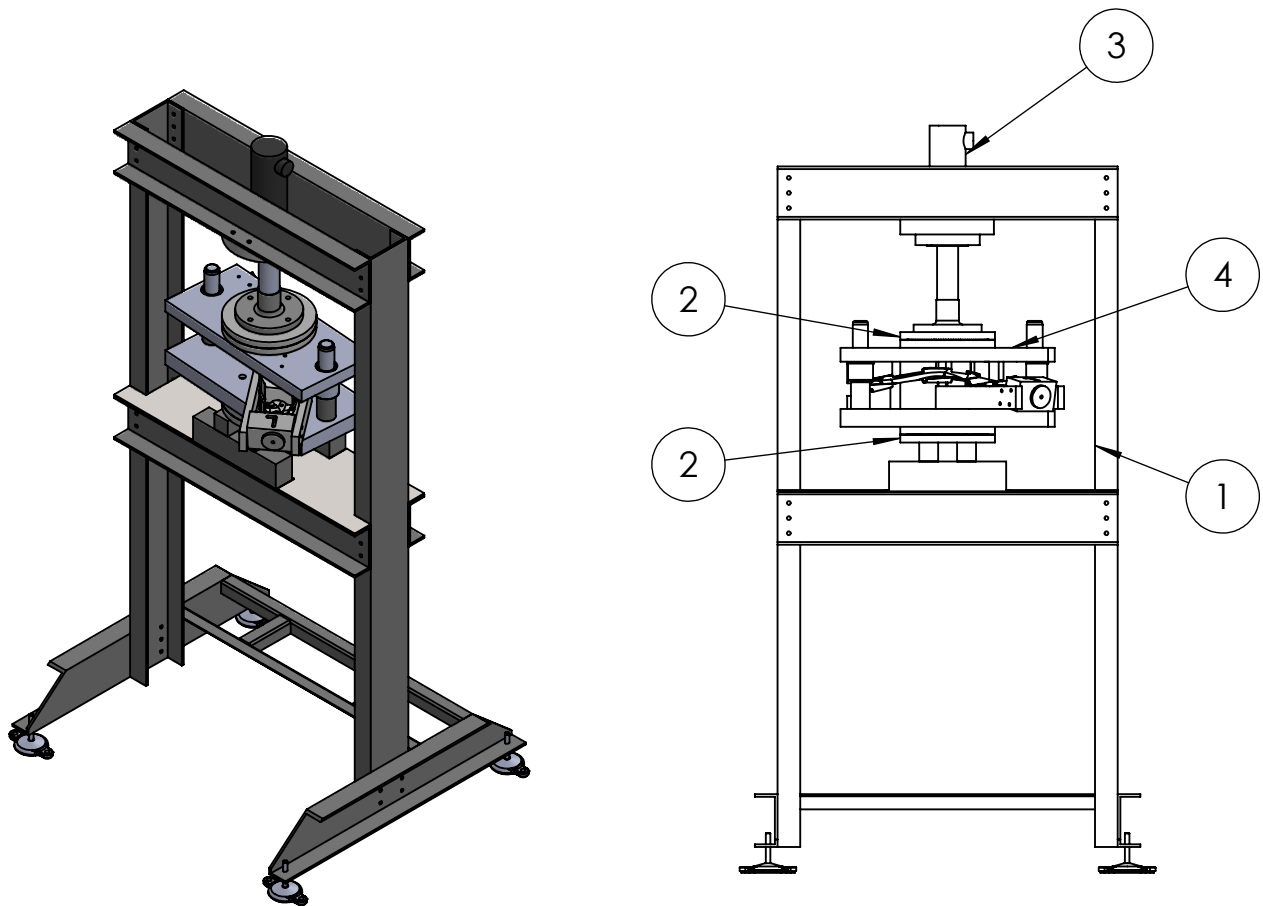
II. Plànols



4	Conjunt MATRIU PORTAMOTLLOS	1	-	4.00
3	Conjunt PISTÓ HIDRÀULIC	1	-	3.00
2	Conjunt RODAMENT	2	-	2.00
1	Conjunt ESTRUCTURA PREMSA	1	-	1.00
Marca	Denominació i observacions	Nombre de peces	Material	Nº Plànol

		Pol. Pla de la Font, parc 1 17832 - Crespià (Girona) www.technigas.com Telf. +34 972 57 09 88		MATERIAL:	-
				RAW MATERIAL:	-
				TREATMENT:	-
EDIT		NAME	DATE	SURF.TREATMENT	-
	DRAWED	A.Jovanet	-	HARDNESS:	-
	CHECHED	X.Saus	-	WEIGHT:	-
DESCRIPTION:				GENERAL TOLERANCES:	ISO 2768-fH
Conjunt premsa hidràulica per soldadura de tubs d'escapament Vertigo				DATA FILE:	-
Nº	0.00	SCALE	FORMAT		
		1/20	DIN A-4		

This drawing belongs to Technigas and its reproduction or distribution to third parties without our authorization is prohibited.

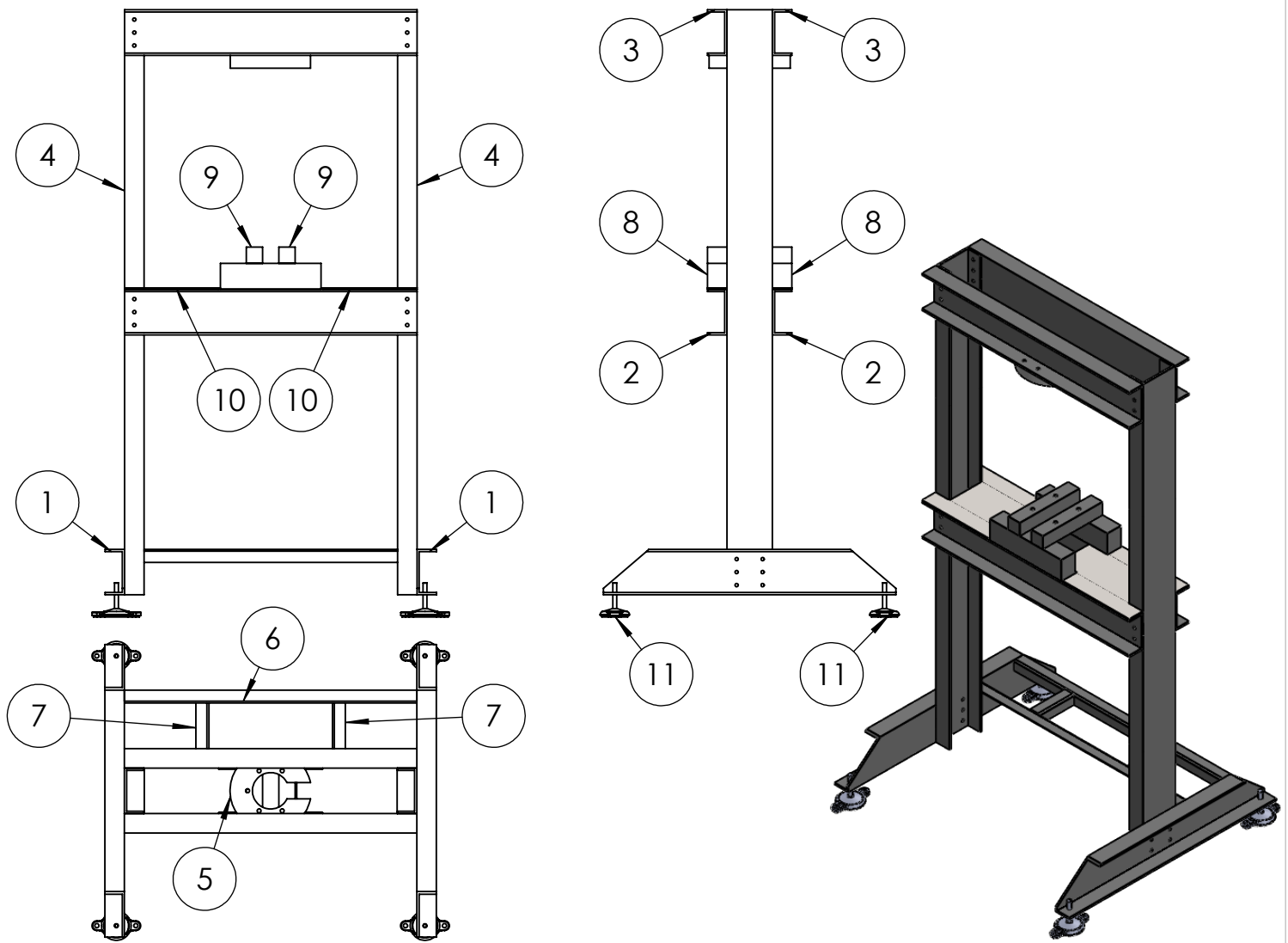

11	Pie ajustable RS PRO	4	-	-
10	Placa embellidora superior	2	ACER F111	1.10
9	Tirants bancada	2	ACER F111	1.09
8	Gruix tirants	2	ACER F111	1.08
7	Suport grup hidràulic curt	2	ACER S235-JR	1.07
6	Suport grup hidràulic	2	ACER S235-JR	1.06
5	Centrador pistó hidràulic	1	ACER F111	1.05
4	UPN 140x1800mm	2	ACER S275-JR	1.04
3	UPN 140x900mm SUPERIORS	2	ACER S275-JR	1.03
2	UPN 140x900mm CENTRALS	2	ACER S275-JR	1.02
1	UPN 140x900mm INFERIORS	2	ACER S275-JR	1.01
Marca	Denominació i observacions	Nombre de peces	Material	Nº Plànol

		Pol. Pla de la Font, parc 1 17832 - Crespià (Girona) www.technigas.com Telf. +34 972 57 09 88		MATERIAL: - RAW MATERIAL: - TREATMENT: - SURF.TREATMENT - HARDNESS: - WEIGHT: - GENERAL TOLERANCES: ISO 2768-fH DATA FILE: -	
EDIT	DRAWN	A.Jovanet	-		
	CHECHED	X.Saus	-		
DESCRIPTION: Conjunt ESTRUCTURA PREMSA				SCALE	FORMAT
Nº 1.00				1/20	DIN A-4
This drawing belongs Technigas being prohibited its reproduction or gives to third without our authorization.					

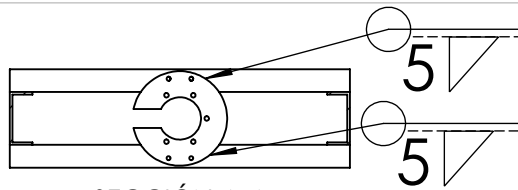

SECCIÓN A-A

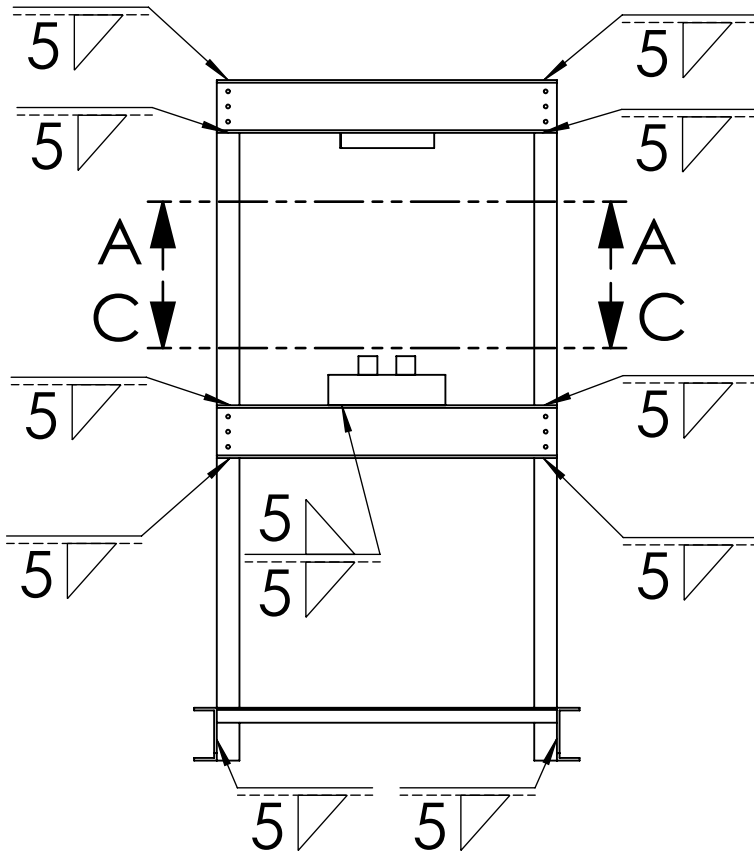

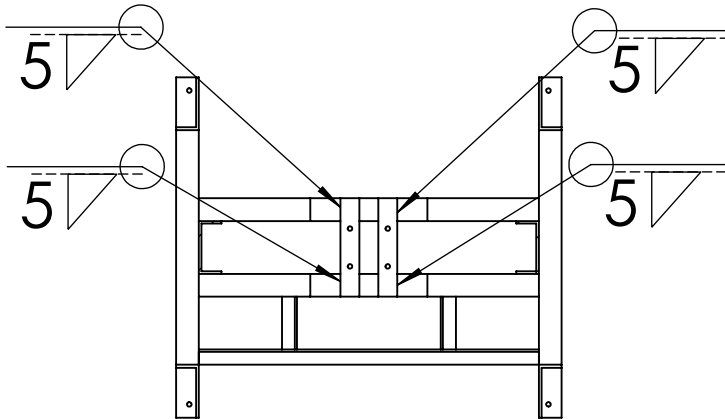

SOLDADURA SIMETRICA EN LOS DOS LADOS DE LA ESTRUCTURA

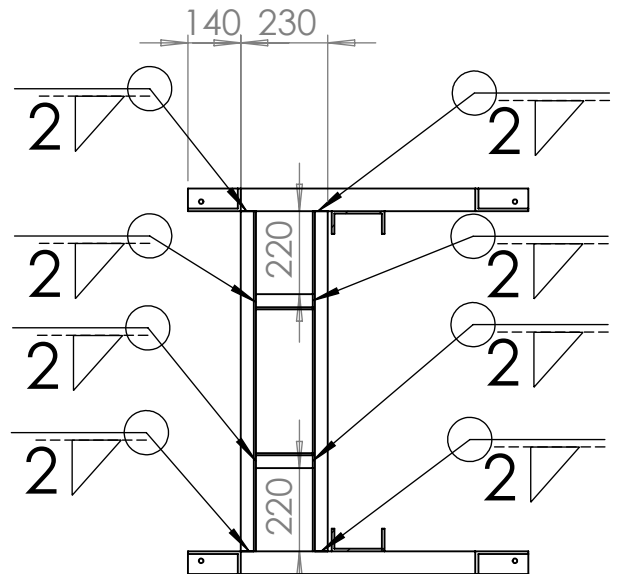
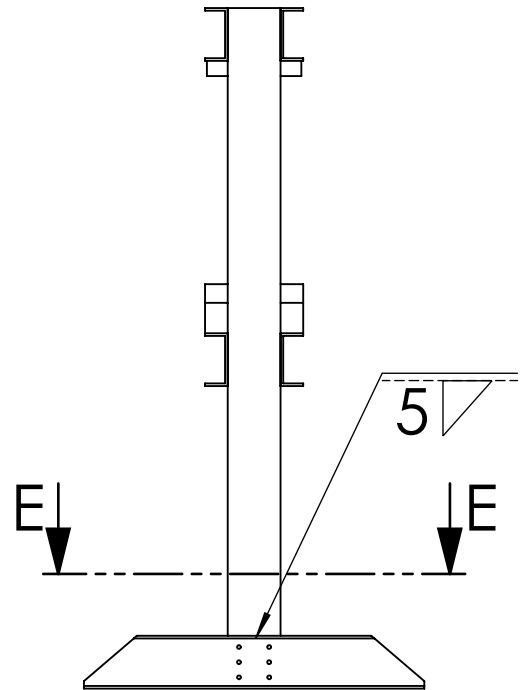

SECCIÓN C-C



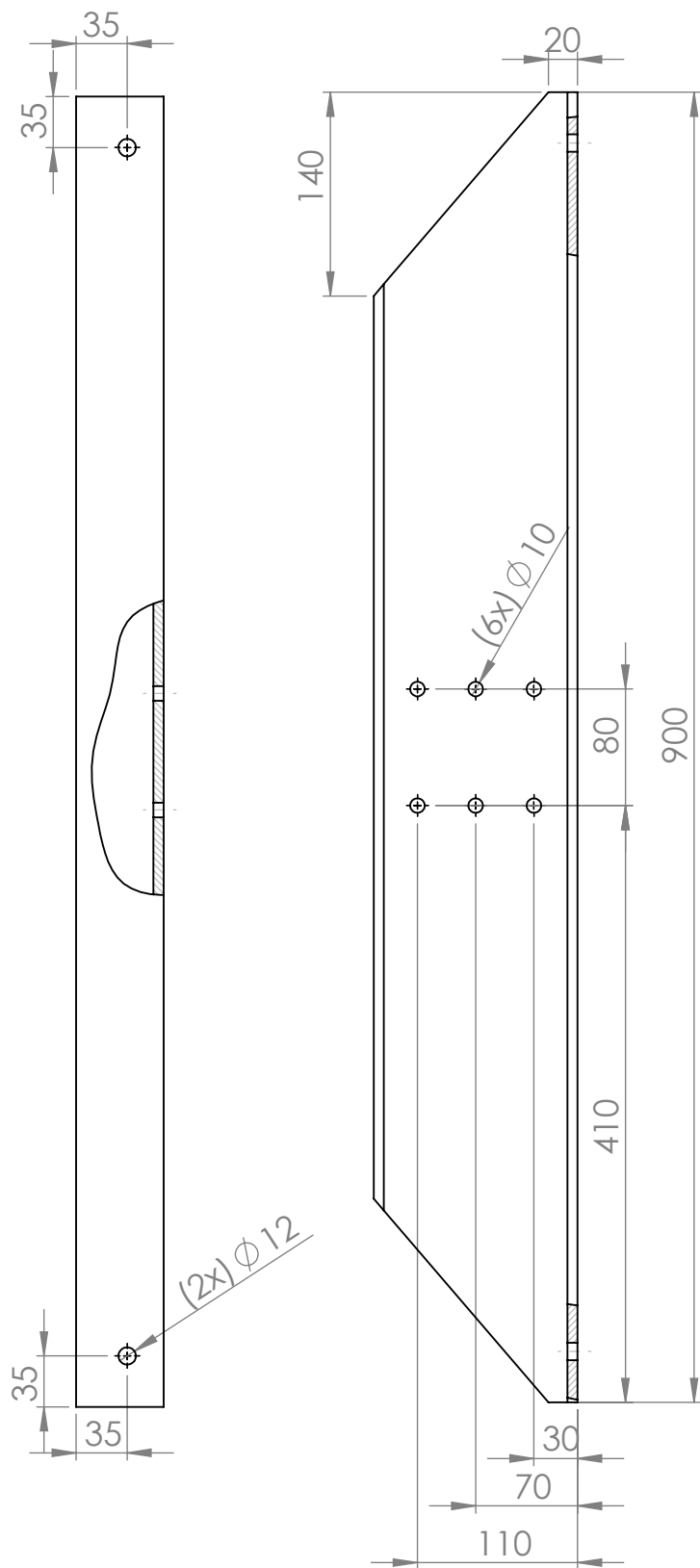

SECCIÓN E-E

			Pol. Pla de la Font, parc 1 17832 - Crespià (Girona) www.tecnigas.com Telf. +34 972 57 09 88		MATERIAL:	-
					RAW MATERIAL:	-
EDIT		NAME	DATE	TREATMENT:		-
		A.Jovanet	-	SURF.TREATMENT		-
		X.Saus	-	HARDNESS:		-
DESCRIPTION:				WEIGHT:		-
Conjunt SOLDAT ESTRUCTURA PREMSA				GENERAL TOLERANCES:		ISO 2768-fH
REF.				DATA FILE:		-
1.00_1				SCALE	FORMAT	
				1/20	DIN A-4	
This drawing belongs Tecnigas being prohibited its reproduction or gives to third without our authorization.						



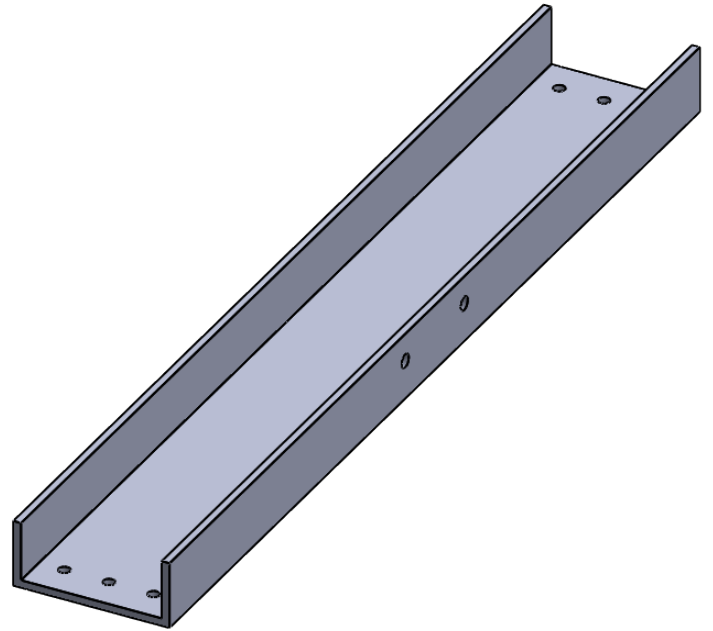
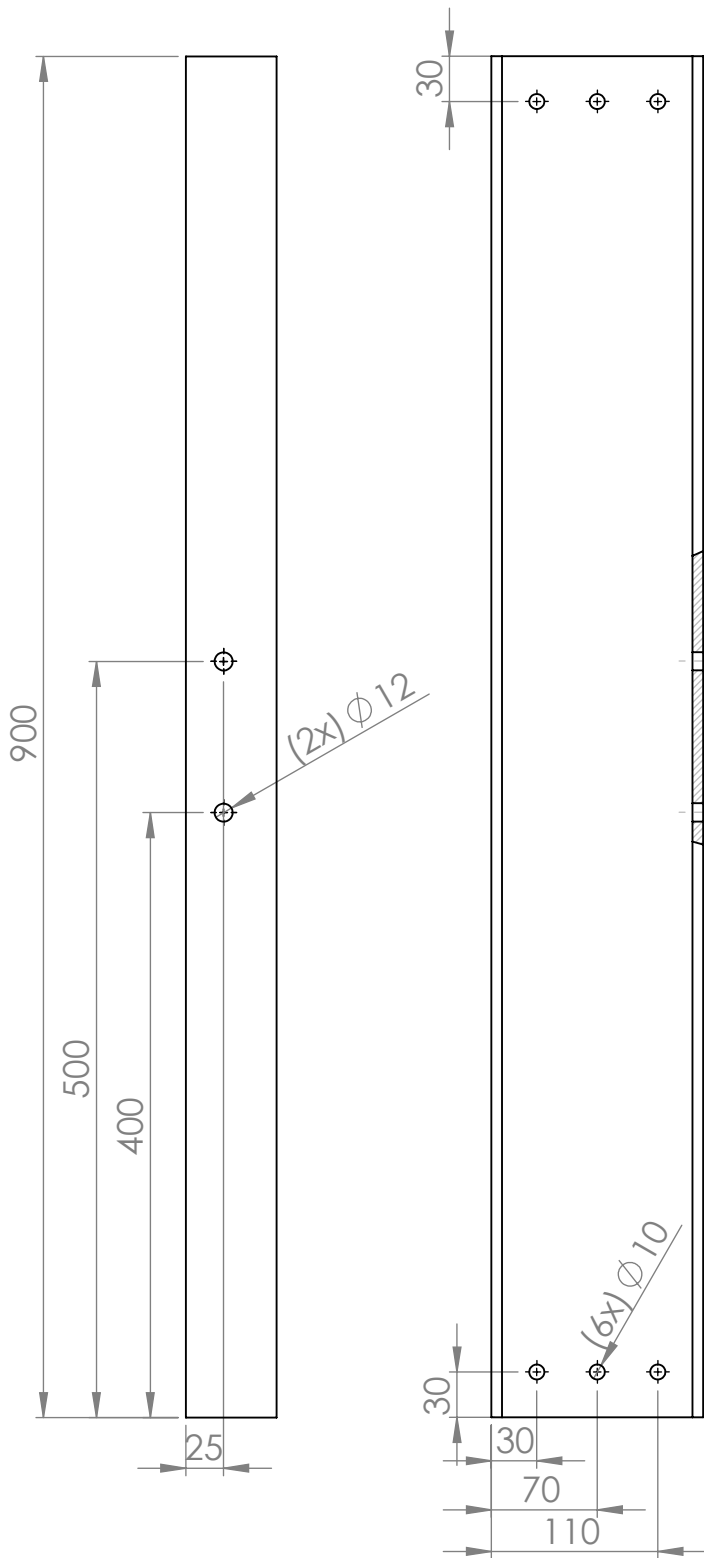

2 UNITATS

			Pol. Pla de la Font, parc 1 17832 - Crespià (Girona) www.technigas.com Telf. +34 972 57 09 88		MATERIAL: ACER S275-JR	
					RAW MATERIAL: -	
					TREATMENT: -	
EDIT			NAME		SURF.TREATMENT	
			A.Jovanet		-	
			X.Saus		-	
			DATE		HARDNESS:	
			-		-	
			-		WEIGHT: 16.4 kg/m	
DESCRIPTION:					GENERAL TOLERANCES: ISO 2768-fH	
UPN 140x900mm INFERIORS					DATA FILE: -	
Nº					SCALE	
1.01					1/5	
					FORMAT	
					DIN A-4	
						
This drawing belongs Tecnigas being prohibited its reproduction or gives to third without our authorization.						



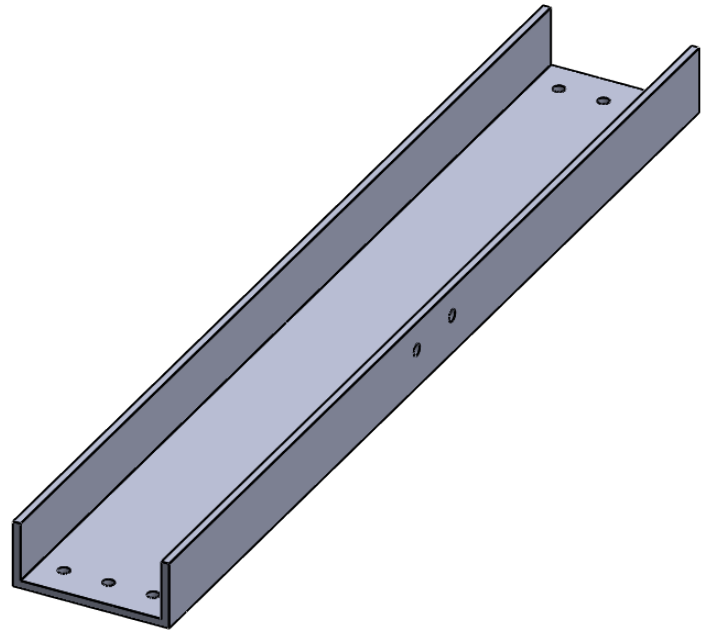
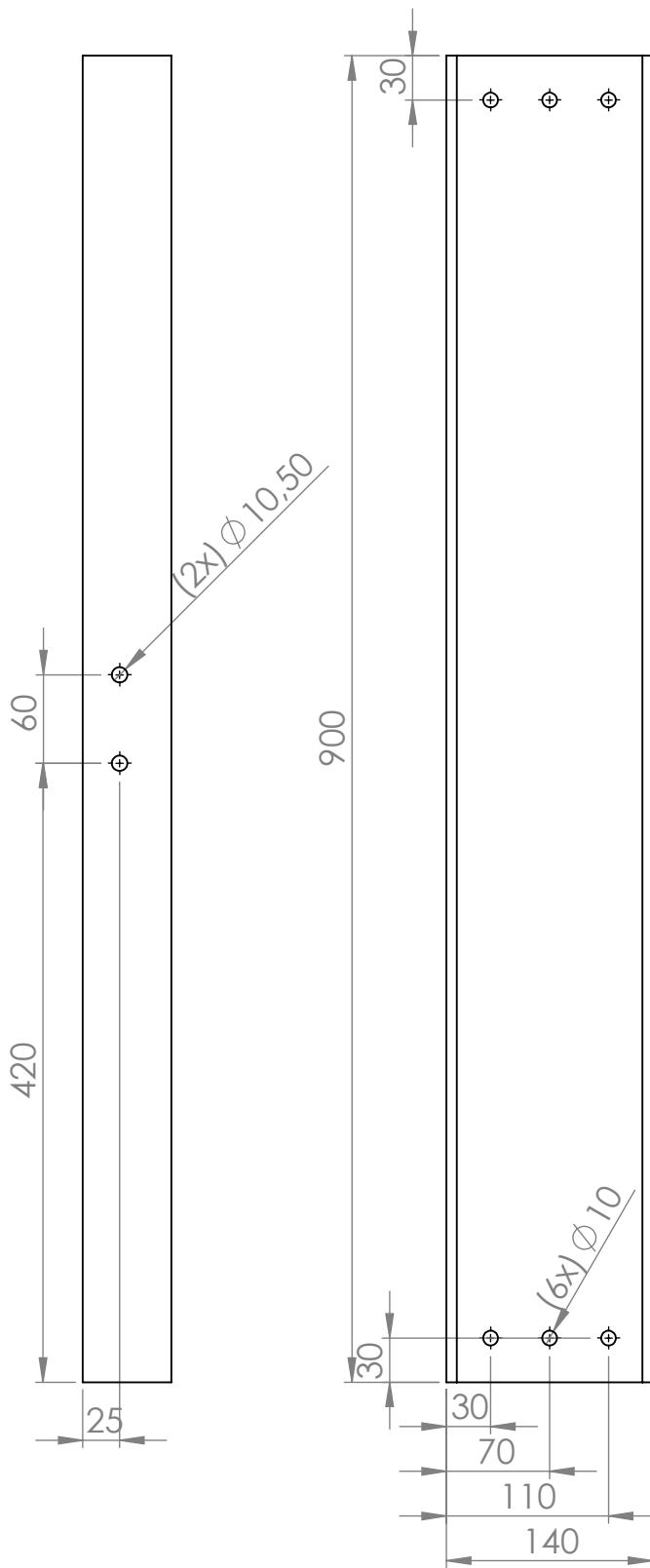

2 UNITATS

			Pol. Pla de la Font, parc 1 17832 - Crespià (Girona) www.technigas.com Telf. +34 972 57 09 88		MATERIAL:	ACER S275-JR	
			EDIT		NAME	DATE	RAW MATERIAL:
	DRAWED	A.Jovanet	-	TREATMENT:	-	SURF.TREATMENT	-
	CHECHED	X.Saus	-	WEIGHT:	16.4 kg/m	HARDNESS:	-
DESCRIPTION:					GENERAL TOLERANCES:	ISO 2768-fH	
UPN 140x900mm CENTRALS					DATA FILE:	-	
Nº	1.02			SCALE	1/5	FORMAT	DIN A-4
							
This drawing belongs Tecnigas being prohibited its reproduction or gives to third without our authorization.							



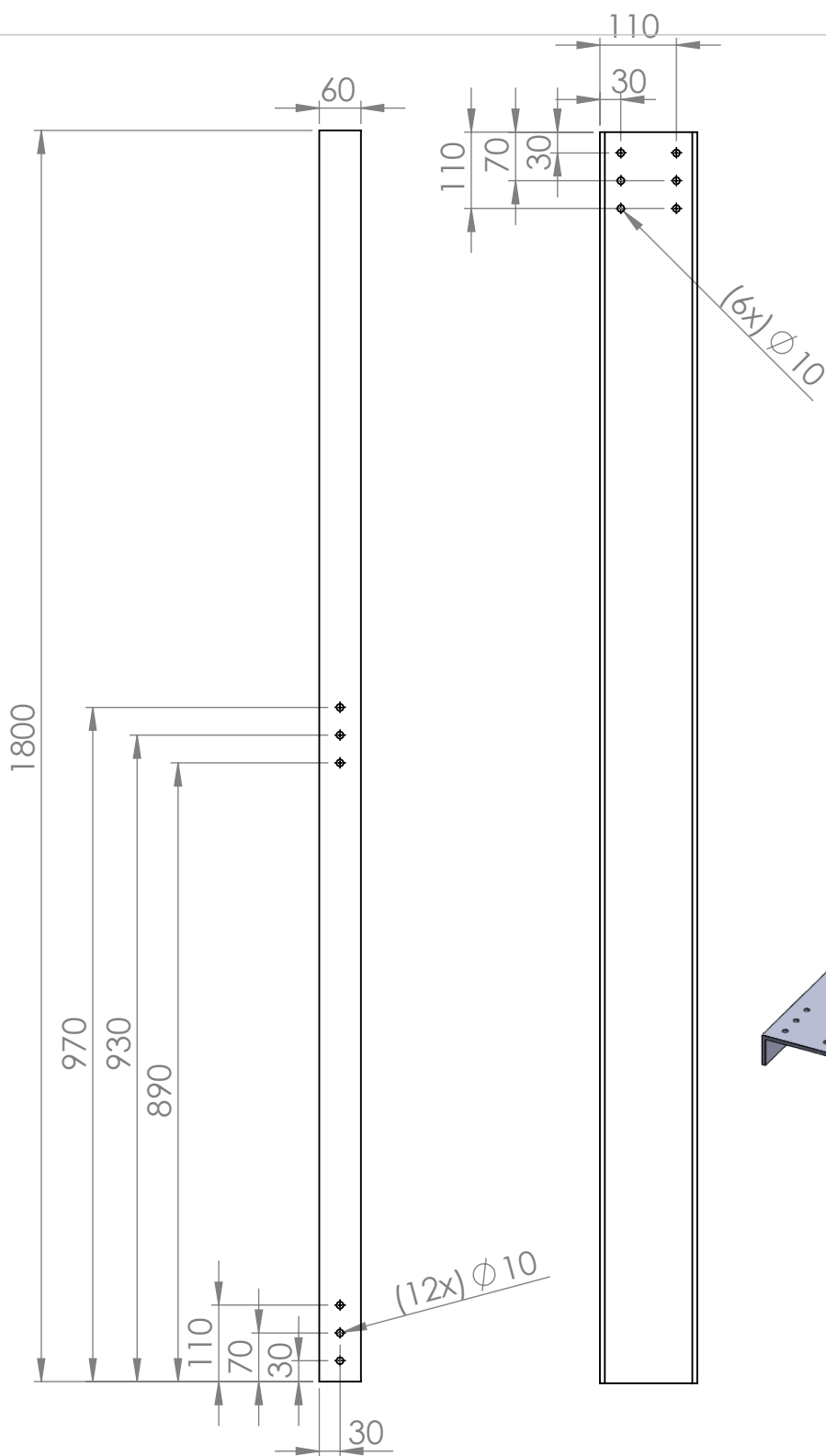

2 UNITATS

		Pol. Pla de la Font, parc 1 17832 - Crespià (Girona) www.technigas.com Telf. +34 972 57 09 88		MATERIAL:	ACER S275-JR
		EDIT		RAW MATERIAL:	-
DRAWN		NAME	A.Jovanet	TREATMENT:	-
CHECKED		DATE	-	SURF.TREATMENT	-
DESCRIPTION: UPN 140x900mm SUPERIORS		HARDNESS:	-	WEIGHT:	16.4 kg/m
Nº 1.03		GENERAL TOLERANCES:	ISO 2768-fH	DATA FILE:	-
		SCALE 1/5	FORMAT DIN A-4		
This drawing belongs to Technigas and its reproduction or use by third parties without our authorization is prohibited.					



2 UNITATS

TOTS ELS FORATS PASSANTS

		Pol. Pla de la Font, parc 1 17832 - Crespià (Girona) www.technigas.com Telf. +34 972 57 09 88		MATERIAL:	ACER S275-JR
		EDIT		RAW MATERIAL: -	
DRAWED		NAME A.Jovanet	DATE -	TREATMENT: -	
CHECHED		X.Saus	-	SURF.TREATMENT -	
DESCRIPTION: UPN 140x1800mm				WEIGHT: 16.4 kg/m	
Nº 1.04				GENERAL TOLERANCES: ISO 2768-fH	
				DATA FILE: -	
				SCALE 1/10	FORMAT DIN A-4
					
This drawing belongs Tecnigas being prohibited its reproduction or gives to third without our authorization.					

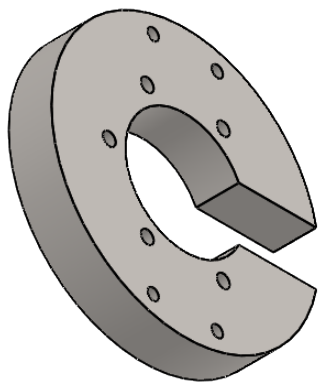
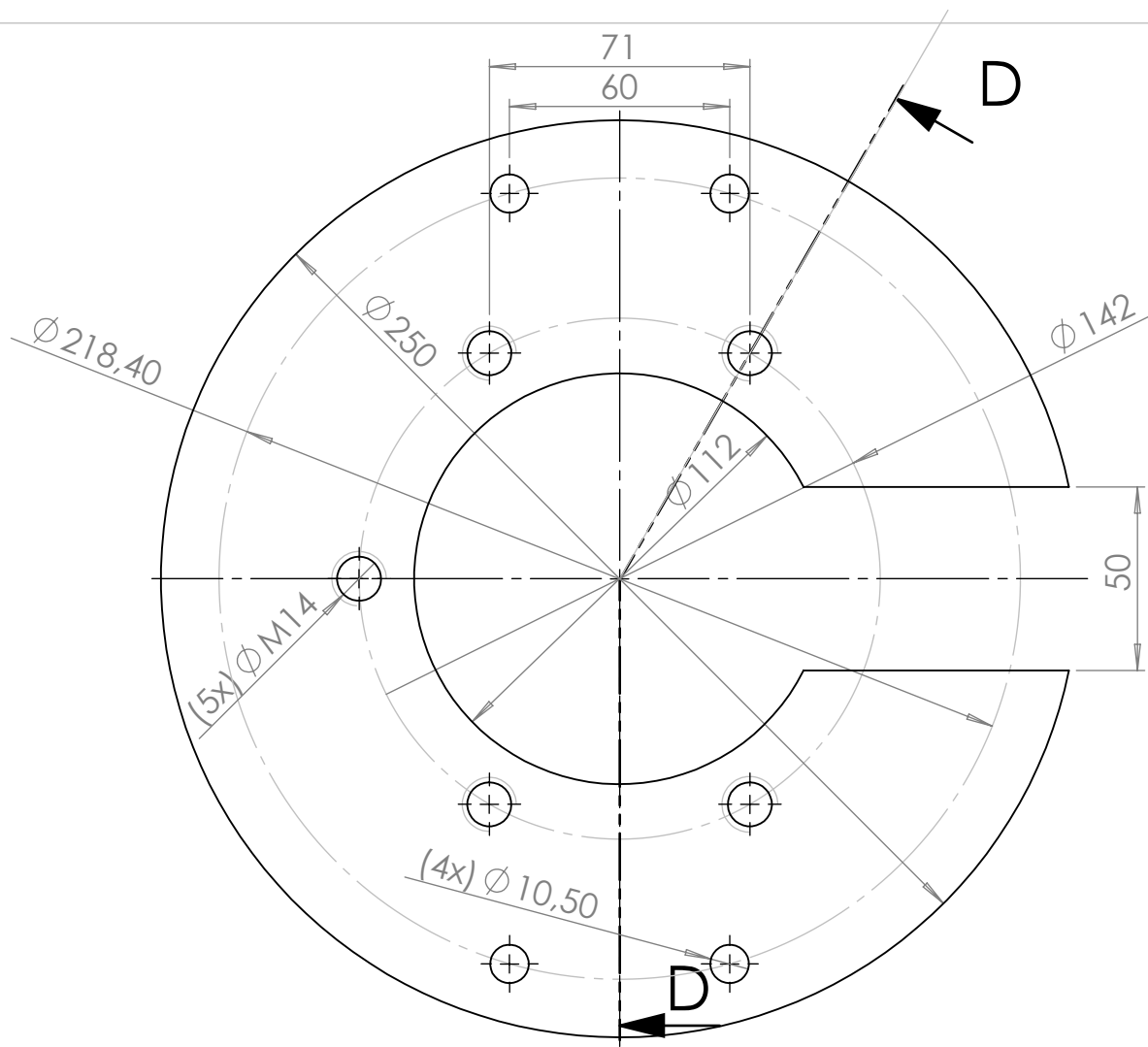
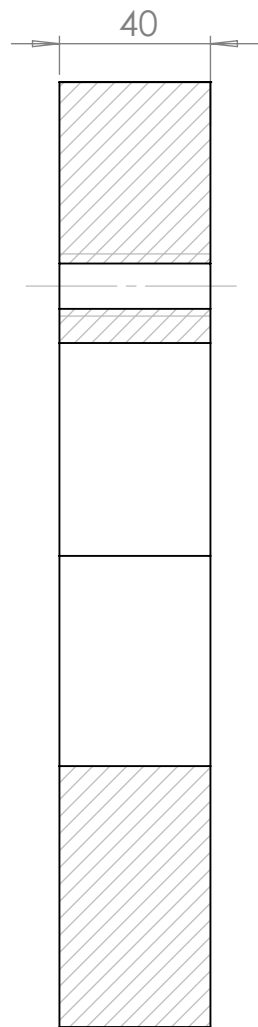

SECCIÓN D-D
ESCALA 1 : 2



Pol. Pla de la Font, parc 1
17832 - Crespià (Girona)
www.technigas.com
Telf. +34 972 57 09 88

MATERIAL: ACER F111

MATERIAL BRUT: -

TRACTAMENT: -

TRAC. SUPERFICIAL: -

DURESA: -

PES: -

TOLERÀNCIES GENERALS ISO 2768-fH

ARXIU DE DADES: -

EDICIÓ	NOM	DATA
-	A.Jovanet	-
-	X.Saus	-



DESCRIPTIÓ:
Centrador pistó hidràulic

Nº
1.05

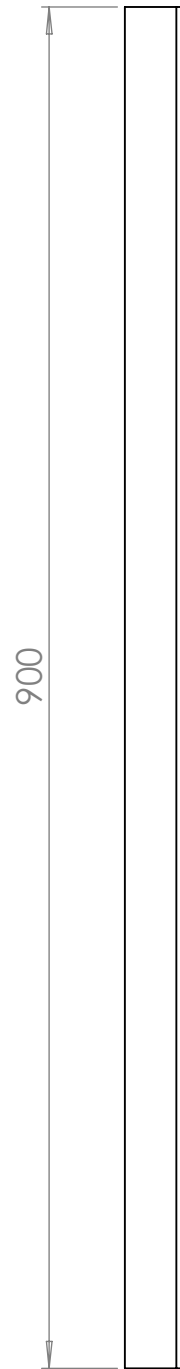
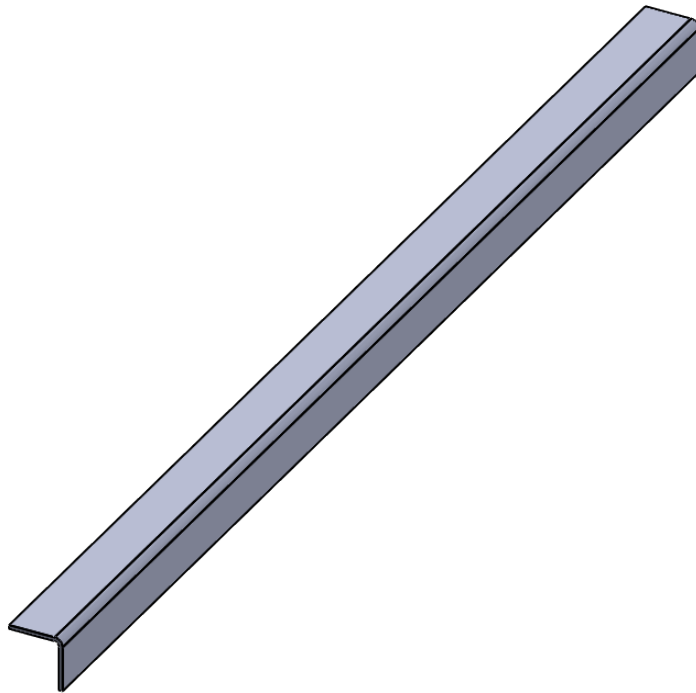
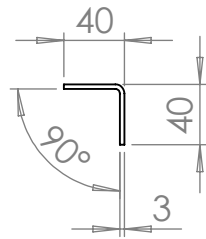
ESCALA 1/2	FORMAT DIN A-4	
----------------------	--------------------------	--



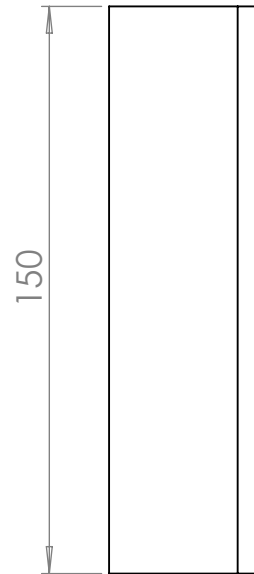
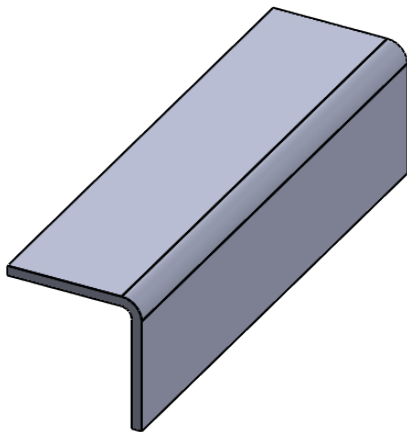
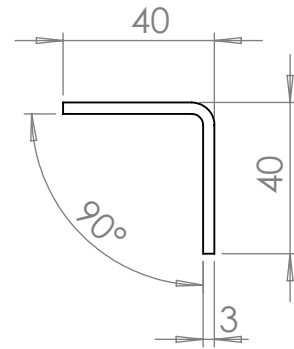

2 UNITATS

		Pol. Pla de la Font, parc 1 17832 - Crespià (Girona) www.technigas.com Telf. +34 972 57 09 88		MATERIAL:	ACER S235-JR	
		EDIT -		RAW MATERIAL:	-	
DRAWED A.Jovanet		NAME	DATE	TREATMENT:	-	
CHECHED X.Saus		A.Jovanet	-	SURF.TREATMENT	-	
DESCRIPTION: Suport grup hidràulic				HARDNESS:	-	
Nº 1.06				WEIGHT:	-	
SCALE 1/5				GENERAL TOLERANCES:	ISO 2768-fH	
FORMAT DIN A-4				DATA FILE:	-	
						
This drawing belongs Tecnigas being prohibited its reproduction or gives to third without our authorization.						



2 UNITATS

		Pol. Pla de la Font, parc 1 17832 - Crespià (Girona) www.tecnigas.com Telf. +34 972 57 09 88		MATERIAL:	ACER S235-JR
		EDIT		RAW MATERIAL:	-
DRAWED		NAME	DATE	TREATMENT:	-
CHECHED		A.Jovanet	-	SURF.TREATMENT	-
DESCRIPTION: Suport grup hidràulic curt		X.Saus	-	HARDNESS:	-
Nº 1.07				WEIGHT:	-
				GENERAL TOLERANCES:	ISO 2768-fH
				DATA FILE:	-
				SCALE	FORMAT
				1/2	DIN A-4
					
This drawing belongs Tecnigas being prohibited its reproduction or gives to third without our authorization.					

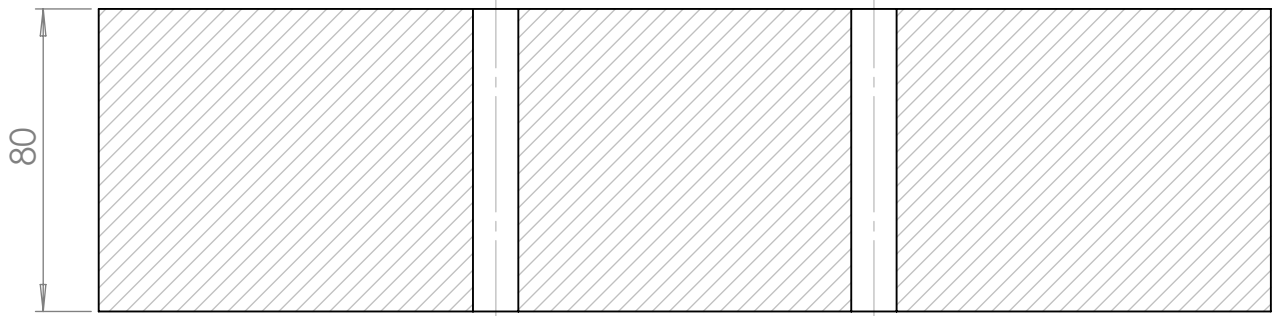

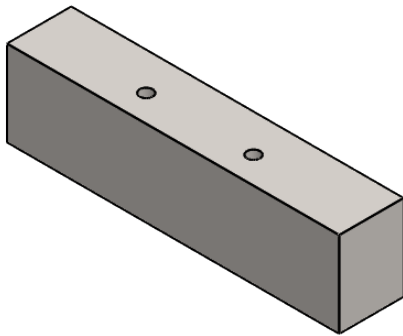
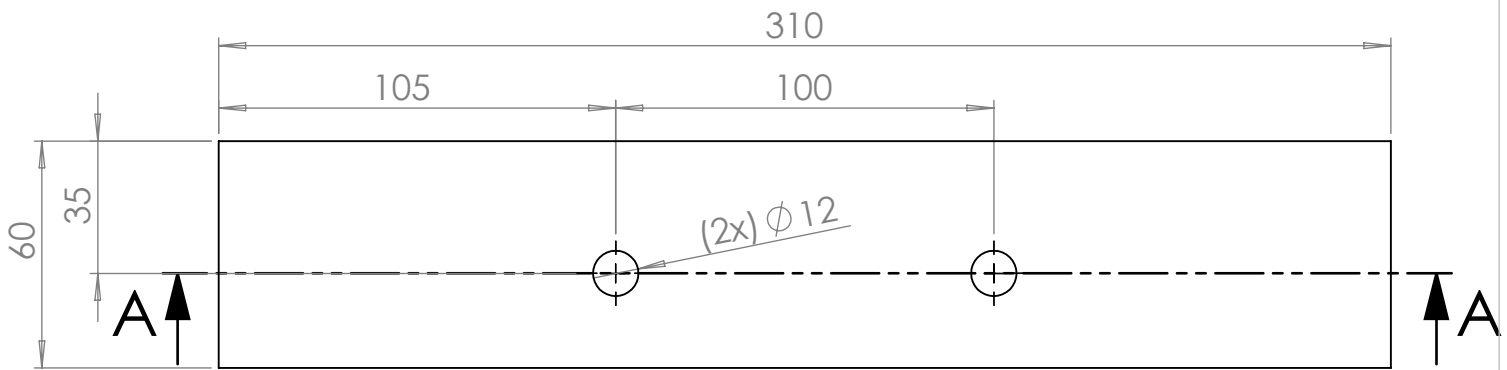

SECCIÓN A-A

ESCALA 1 : 2



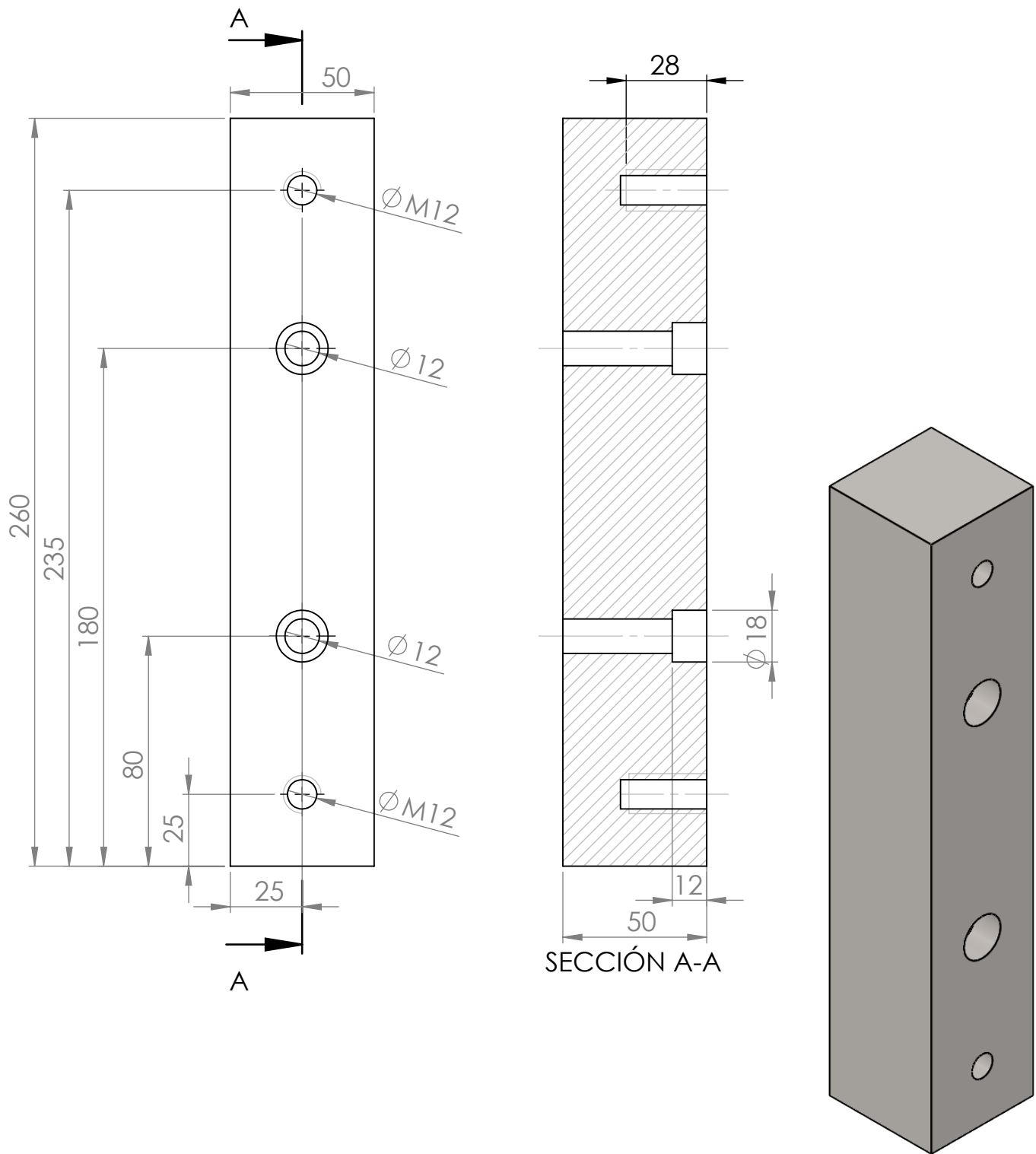

2 UNITATS

			Pol. Pla de la Font, parc 1 17832 - Crespià (Girona) www.technigas.com Telf. +34 972 57 09 88		MATERIAL: ACER F111	
EDIT			NAME		RAW MATERIAL: -	
-			A.Jovanet		TREATMENT: -	
DRAWED			DATE		SURF.TREATMENT -	
-			-		HARDNESS: -	
CHECHED			X.Saus		WEIGHT: -	
-			-		GENERAL TOLERANCES: ISO 2768-fH	
DESCRIPTION:					DATA FILE: -	
Gruix tirants						
Nº					SCALE	
1.08					1/2	
					FORMAT	
					DIN A-4	
						
This drawing belongs to Technigas being prohibited its reproduction or gives to third without our authorization.						



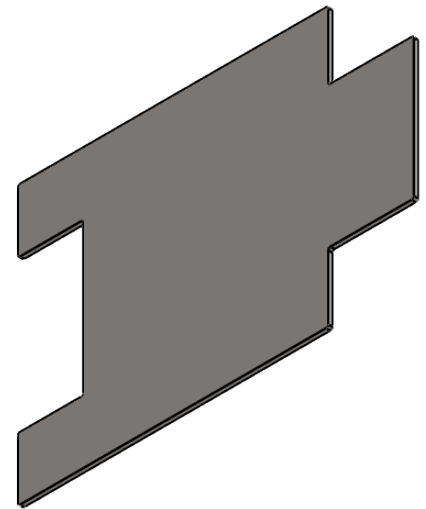
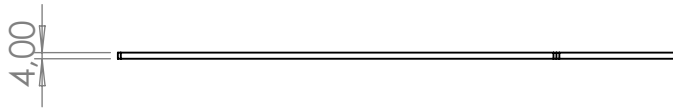
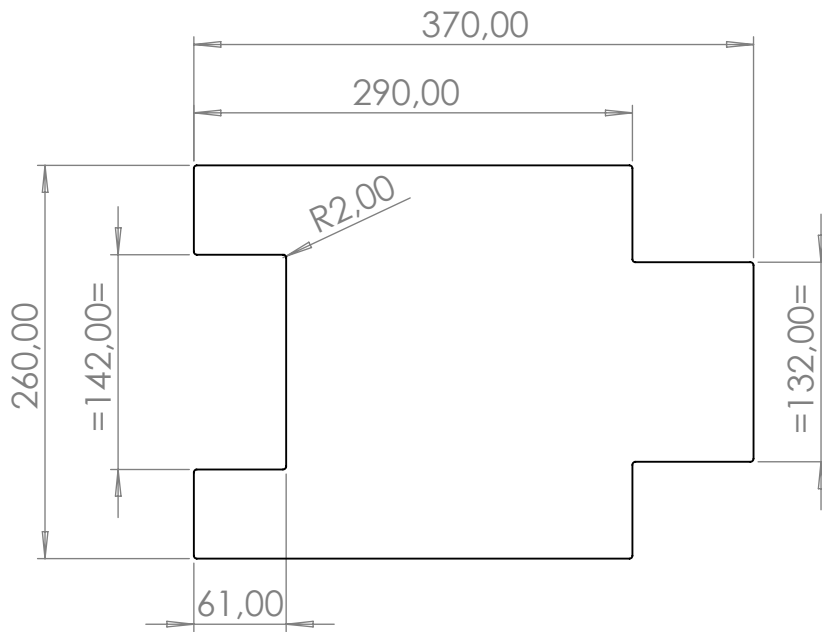

2 UNITATS

		Pol. Pla de la Font, parc 1 17832 - Crespià (Girona) www.technigas.com Telf. +34 972 57 09 88		MATERIAL:	ACER F111
		EDIT		RAW MATERIAL:	-
DRAWED		NAME	DATE	TREATMENT:	-
CHECKED		A.Jovanet	-	SURF.TREATMENT	-
DESCRIPTION: Tirants bancada		X.Saus	-	HARDNESS:	-
Nº 1.09		GENERAL TOLERANCES: ISO 2768-fH		WEIGHT:	-
SCALE 1/2		DATA FILE: -		FORMAT DIN A-4	
This drawing belongs to Technigas being prohibited its reproduction or gives to third without our authorization.					



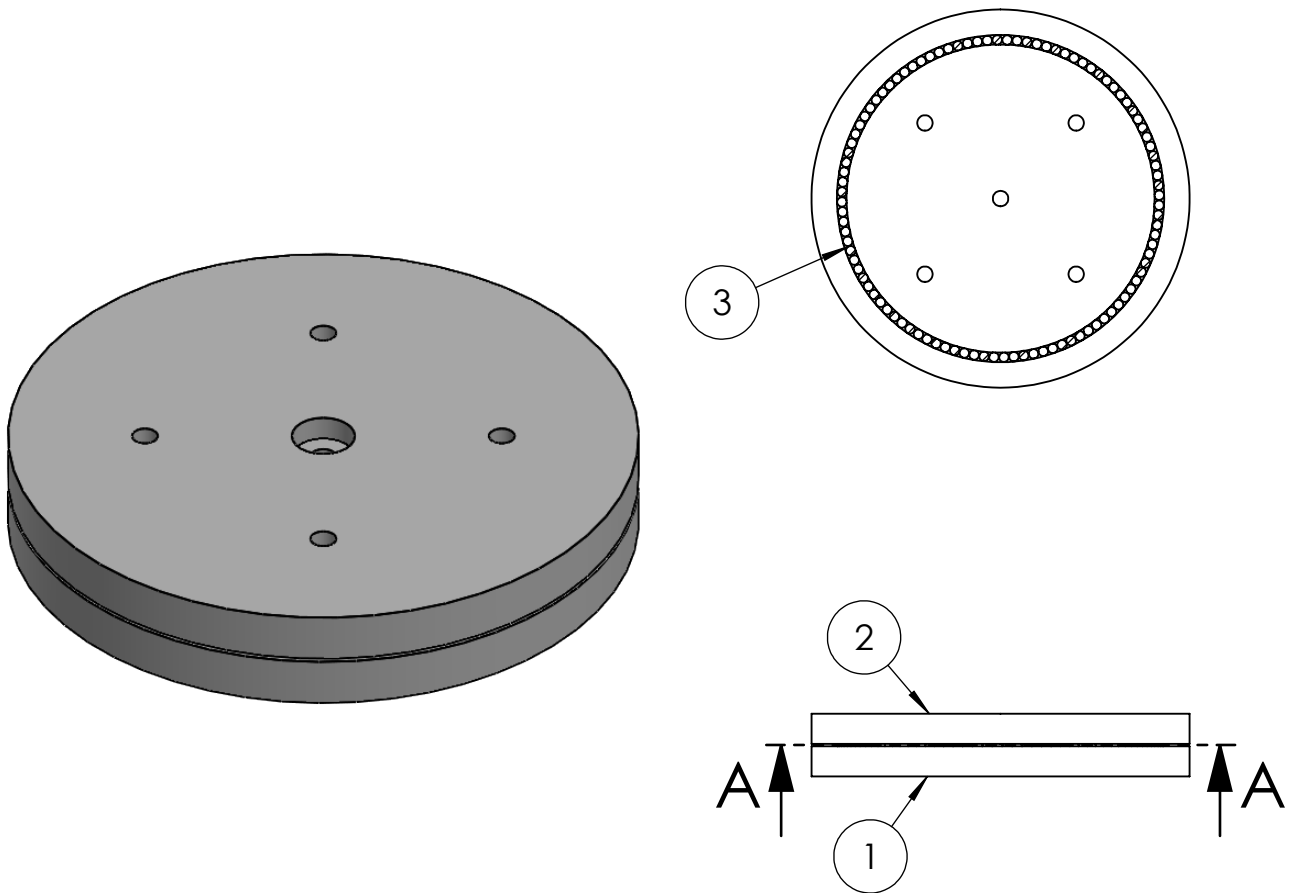

2 UNITATS

			Pol. Pla de la Font, parc 1 17832 - Crespià (Girona) www.technigas.com Telf. +34 972 57 09 88		MATERIAL: ACER F111	
EDIT			NAME		RAW MATERIAL: -	
-			A.Jovanet		TREATMENT: -	
-			X.Saus		SURF.TREATMENT -	
DESCRIPTION:			DATE		HARDNESS: -	
Placa embellidora superior			-		WEIGHT: -	
REF.			GENERAL TOLERANCES: ISO 2768-fH		DATA FILE: -	
1.10			SCALE		FORMAT	
			1/5		DIN A-4	
						
This drawing belongs Tecnigas being prohibited its reproduction or gives to third without our authorization.						



3	<i>Bola rodament D6.3</i>	100	ACER 52100	-
2	<i>Base rodament superior</i>	1	ACER 2842	2.02
1	<i>Base rodament inferior</i>	1	ACER 2842	2.01
Marca	Denominació i observacions	Nombre de peces	Material	Nº Plànol

		Pol. Pla de la Font, parc 1 17832 - Crespià (Girona) www.technigas.com Telf. +34 972 57 09 88		MATERIAL:	-
				RAW MATERIAL:	-
				TREATMENT:	-
EDIT		NAME	DATE	SURF.TREATMENT	-
	DRAWED	A.Jovanet	-	HARDNESS:	-
	CHECHED	X.Saus	-	WEIGHT:	-
DESCRIPTION:				GENERAL TOLERANCES:	ISO 2768-fH
Conjunt RODAMENT				DATA FILE:	-
Nº		SCALE	FORMAT		
2.00		1/5	DIN A-4		

This drawing belongs to Technigas being prohibited its reproduction or gives to third without our authorization.

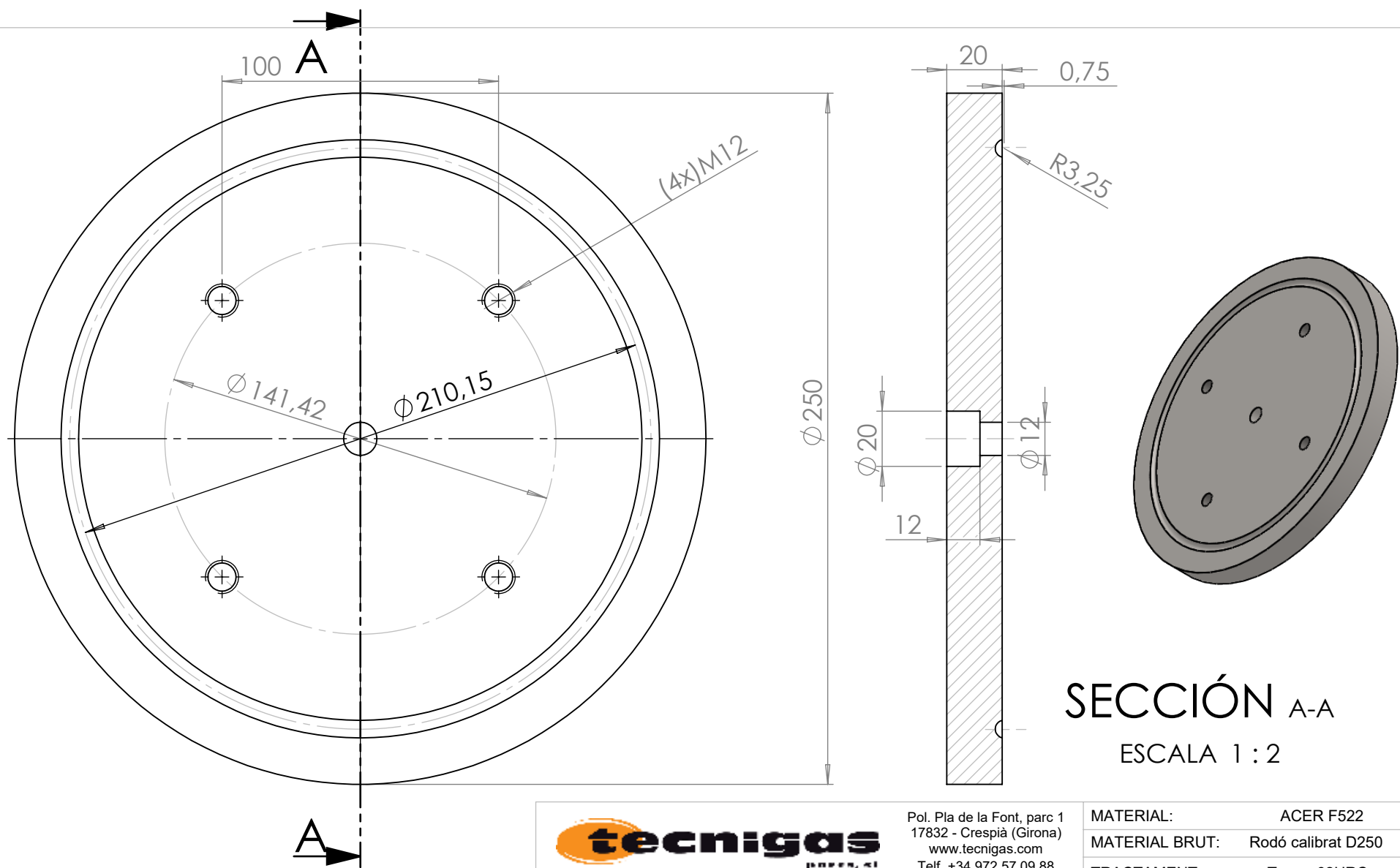

SECCIÓ A-A
ESCALA 1 : 2

FORATS ROSCATS PASSANTS



Pol. Pla de la Font, parc 1
17832 - Crespià (Girona)
www.technigas.com
Telf. +34 972 57 09 88

MATERIAL: ACER F522

MATERIAL BRUT: Rodó calibrat D250

TRACTAMENT: Tremp 62HRC

TRAC. SUPERFICIAL: -

DURESA: -

PES: -

TOLERÀNCIES GENERALS ISO 2768-fH

ARXIU DE DADES: -

EDICIÓ	NOM	DATA
-	A.Jovanet	-
-	X.Saus	-

DESCRIPTIÓ:
Base rodament inferior

Nº
2.01

ESCALA
1/2

FORMAT
DIN A-4



Aquest plànol és de la nostra propietat. No pot ser copiat ni comunicat a terceres persones sense la nostra autorització per escrit.

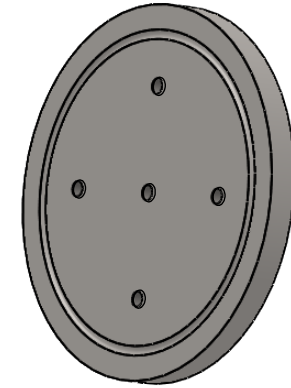
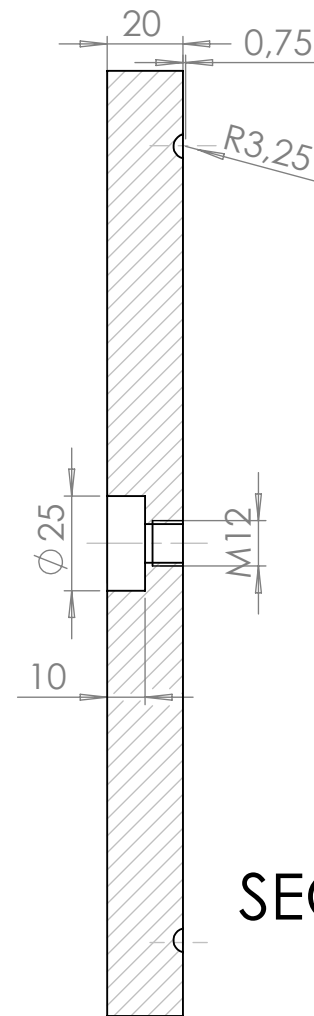
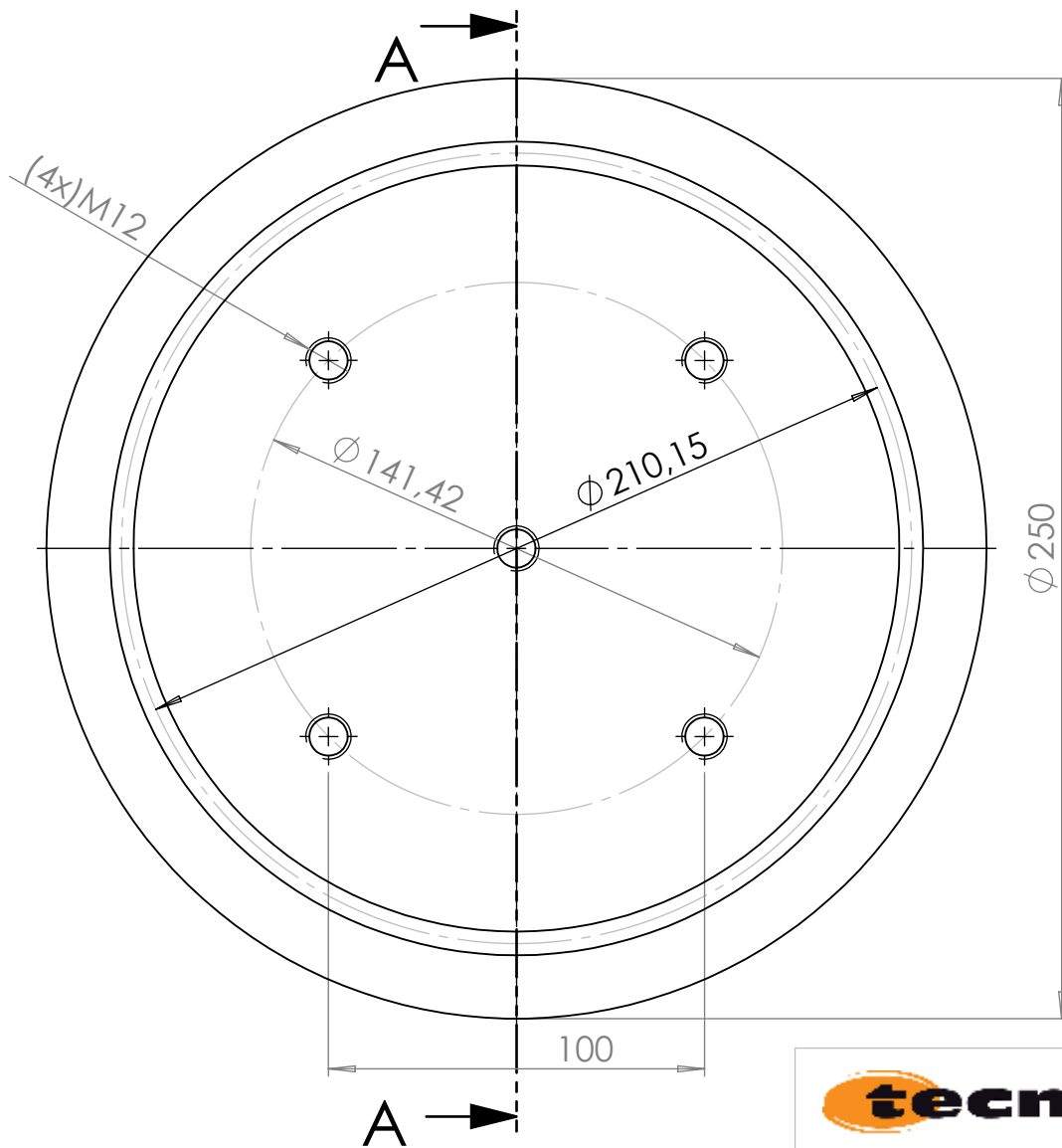

SECCIÓN A-A
ESCALA 1 : 2

FORATS ROSCATS PASSANTS



Pol. Pla de la Font, parc 1
17832 - Crespià (Girona)
www.technigas.com
Telf. +34 972 57 09 88

MATERIAL: ACER F522
MATERIAL BRUT: Rodó calibrat D250
TRACTAMENT: Tremp 62HRC

EDICIÓ	NOM	DATA
-	A.Jovanet	-
-	X.Saus	-

TRAC. SUPERFICIAL: -
DURESA: -
PES: -

DESCRIPTIÓ:
Base rodament superior

TOLERÀNCIES GENERALS ISO 2768-fH
ARXIU DE DADES: -

Nº
2.02



ESCALA
1/2

FORMAT
DIN A-4

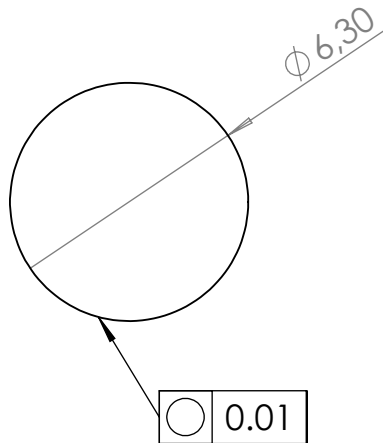
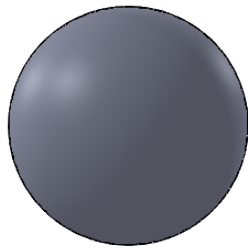



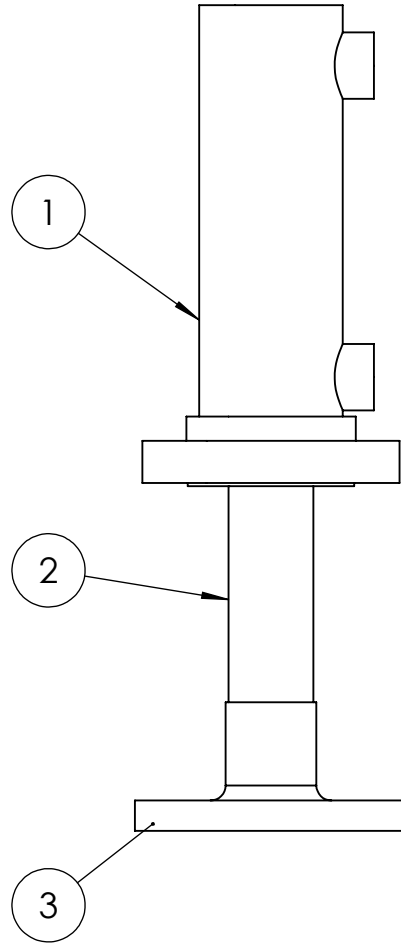
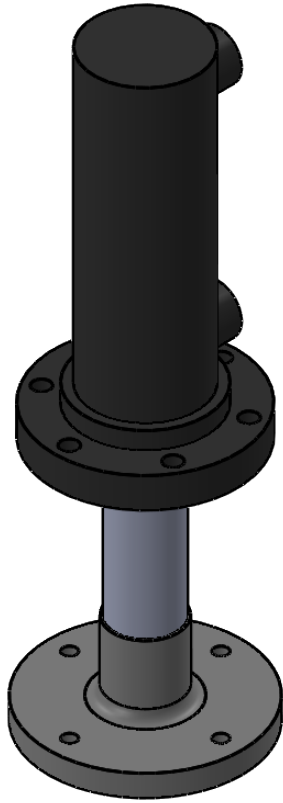

100 UNITATS

		Pol. Pla de la Font, parc 1 17832 - Crespià (Girona) www.tecnigas.com Telf. +34 972 57 09 88		MATERIAL:	ACER AISI 52100
		EDIT		RAW MATERIAL:	-
DRAWED		NAME	A.Jovanet	TREATMENT:	Tremp 62HRC
CHECHED		DATE	-	SURF.TREATMENT	-
DESCRIPTION: Bola rodament D6.3				HARDNESS:	-
Nº 2.03				WEIGHT:	-
				GENERAL TOLERANCES:	ISO 2768-fH
				DATA FILE:	-
				SCALE	FORMAT
				5/1	DIN A-4
					
This drawing belongs Tecnigas being prohibited its reproduction or gives to third without our authorization.					



3	Unio pistó-coixinet	1	ACER F111	3.01
2	Eix pistó	1	-	-
1	Pistó hidràulic	1	-	-
Marca	Denominació i observacions	Nombre de peces	Material	Nº Plànol

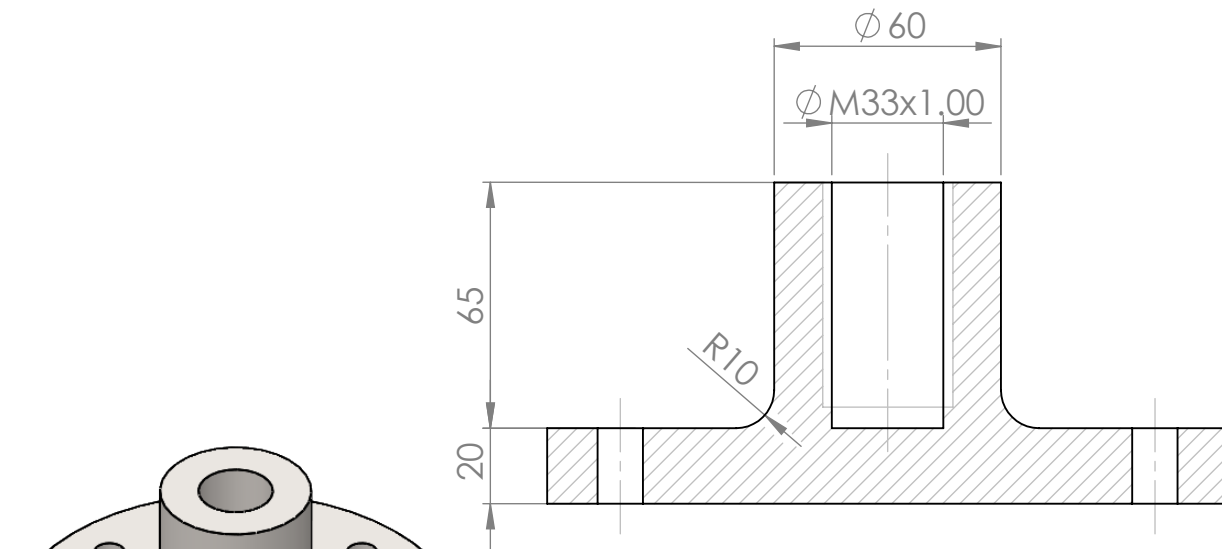

		Pol. Pla de la Font, parc 1 17832 - Crespià (Girona) www.technigas.com Telf. +34 972 57 09 88		MATERIAL:	-
				RAW MATERIAL:	-
				TREATMENT:	-
EDIT		NAME	DATE	SURF.TREATMENT	-
	DRAWED	A.Jovanet	-	HARDNESS:	-
	CHECHED	X.Saus	-	WEIGHT:	-
DESCRIPTION:				GENERAL TOLERANCES:	ISO 2768-fH
Conjunt PISTÓ HIDRÀULIC				DATA FILE:	-
REF.	3.00	SCALE	FORMAT		
		1/5	DIN A-4		

This drawing belongs to Technigas being prohibited its reproduction or gives to third without our authorization.

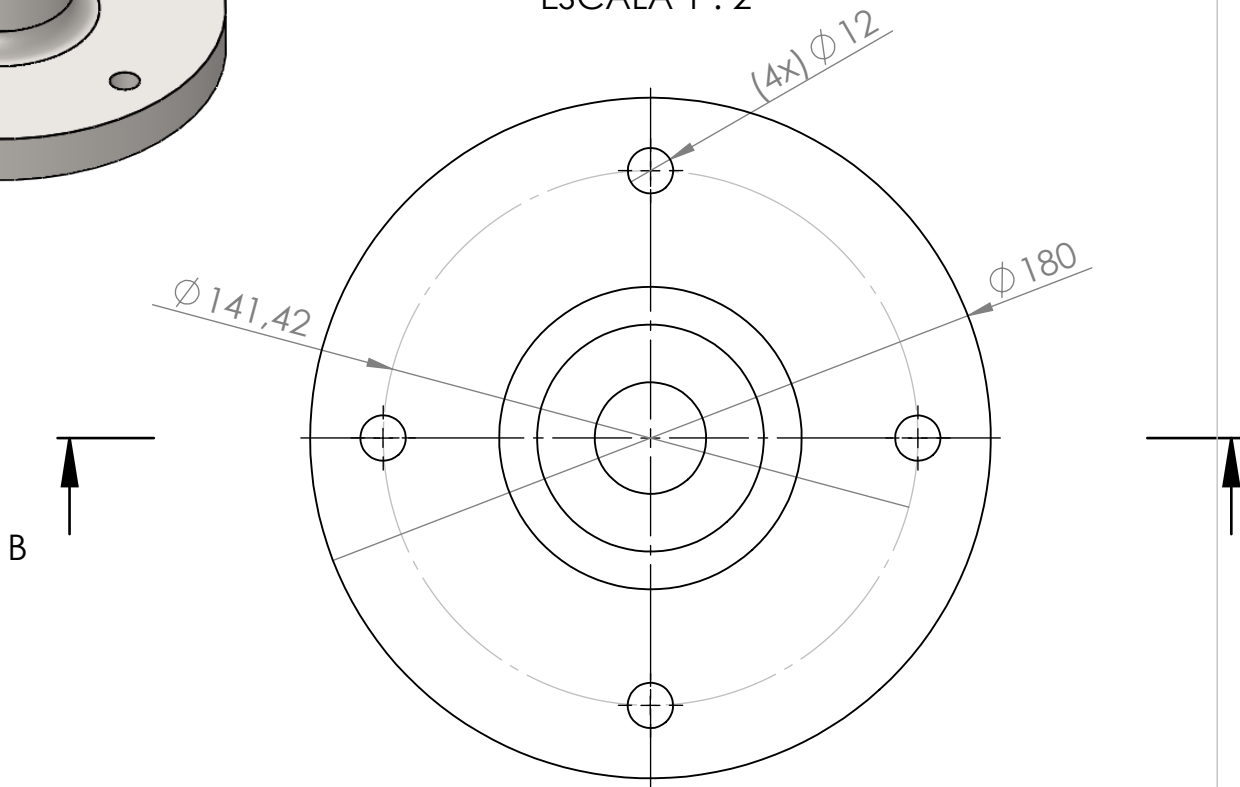

SECCIÓN B-B
ESCALA 1 : 2



		Pol. Pla de la Font, parc 1 17832 - Crespià (Girona) www.technigas.com Telf. +34 972 57 09 88		MATERIAL:	Acer F111
		EDIT		RAW MATERIAL:	Rodó calibrat D180
DRAWED		NAME	A.Jovanet	TREATMENT:	-
CHECHED		CHECHED	X.Saus	SURF.TREATMENT	-
DESCRIPTION: Unió pistó-rodament		DATE	-	HARDNESS:	-
Nº 3.01		DATE	-	WEIGHT:	-
		GENERAL TOLERANCES:	ISO 2768-fH	DATA FILE:	-
		SCALE	1/2	FORMAT	DIN A-4
					
This drawing belongs Technigas being prohibited its reproduction or gives to third without our authorization.					

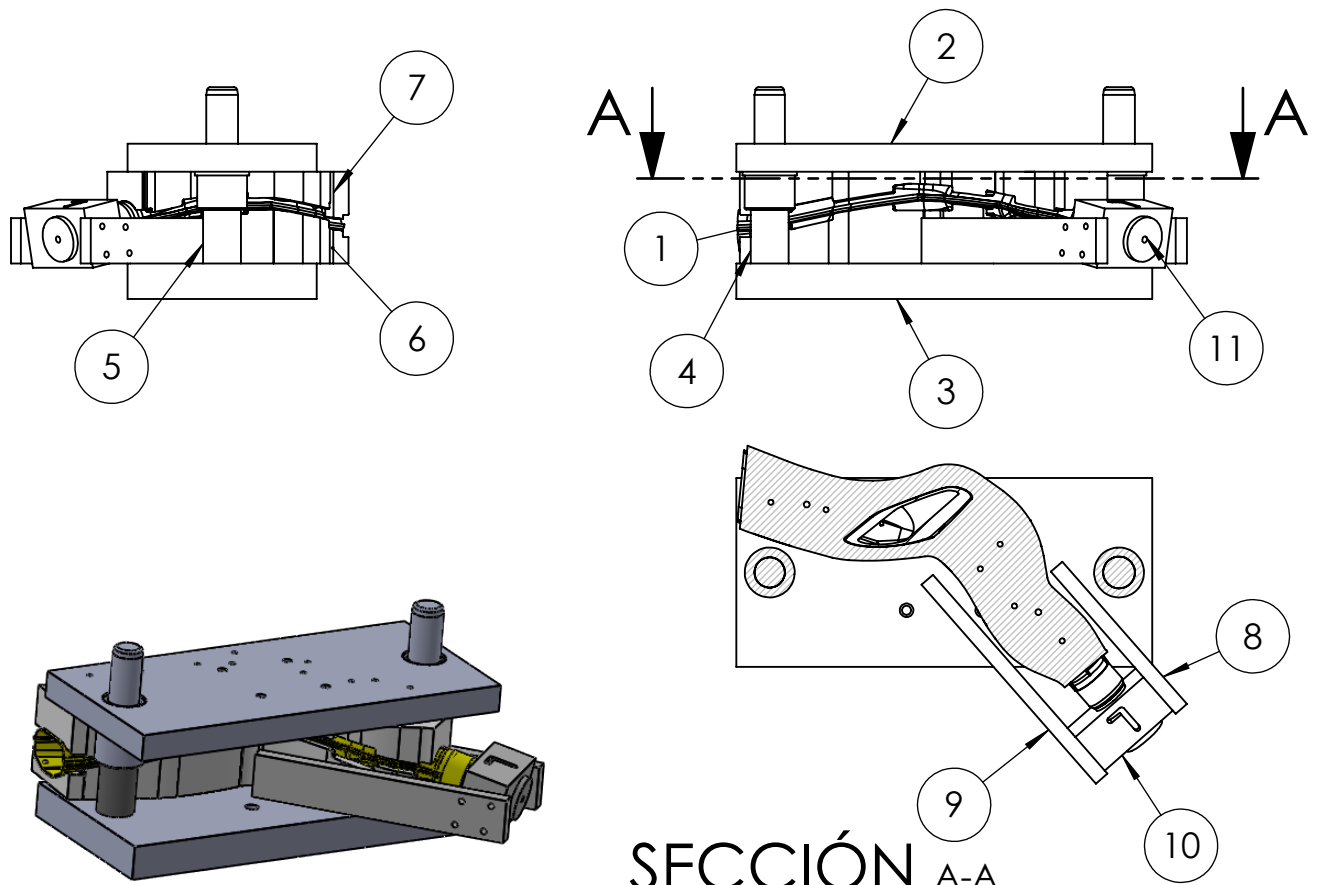

SECCIÓ A-A

ESCALA 1 : 10

11	Casquillo centrador boquilla	1	ACER F111	4.09
10	Centrador casquillo	1	ACER F111	4.08
9	Suport 2 centrador casquillo	1	ACER F111	4.07
8	Suport 1 centrador casquillo	1	ACER F111	4.06
7	Motllo superior	1	DELRIN C POM C	-
6	Motllo inferior	1	DELRIN C POM C	-
5	Tope mecànic D42	1	ACER F111	4.05
4	Tope mecànic D40	1	ACER F111	4.04
3	Placa INFERIOR matriu portamotllos	1	-	4.02 i 4.03
2	Placa SUPERIOR matriu portamotllos	1	-	4.01
1	V-1816 ESCAPE	1	-	-
Marca	Denominació i observacions	Nombre de peces	Material	Nº Plànol



Pol. Pla de la Font, parc 1
17832 - Crespià (Girona)
www.tecnigas.com
Telf. +34 972 57 09 88

MATERIAL: -
RAW MATERIAL: -

TREATMENT: -

EDIT

NAME

DATE

SURF.TREATMENT -

DRAWED

A.Jovanet

-

HARDNESS: -

CHECHED

X.Saus

-

WEIGHT: -

DESCRIPTION:

Conjunt Matriu Portamotllos

GENERAL TOLERANCES: ISO 2768-fH

DATA FILE: -

Nº

4.00

SCALE
1/10



FORMAT
DIN A-4

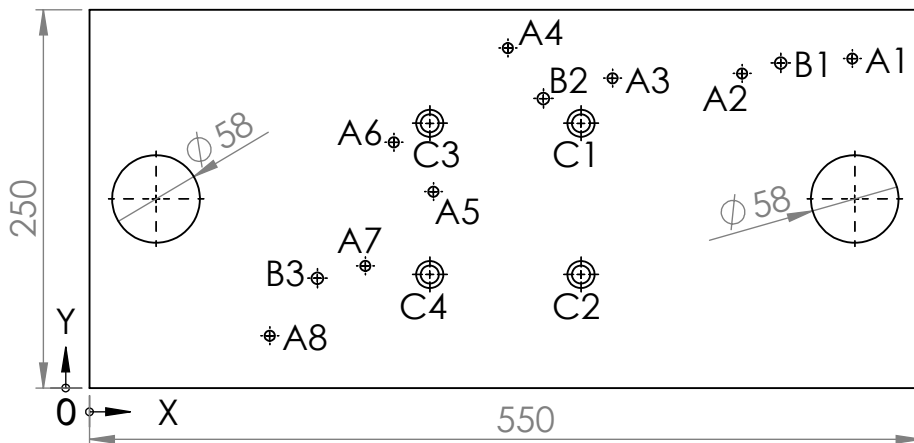

RÓTULO	UBIC X	UBIC Y	TAMAÑO
A1	504,37	217,76	∅ 6,80 POR TODO
A2	431,51	207,92	∅ 6,80 POR TODO
A3	345,82	204,80	∅ 6,80 POR TODO
A4	276,63	224,75	∅ 6,80 POR TODO
A5	227,42	129,79	∅ 6,80 POR TODO
A6	201,23	162,38	∅ 6,80 POR TODO
A7	182,38	80,68	∅ 6,80 POR TODO
A8	119,18	34,48	∅ 6,80 POR TODO
B1	457,02	214,86	∅ 7,75 POR TODO
B2	300,12	191,37	∅ 7,75 POR TODO
B3	150,67	72,53	∅ 7,75 POR TODO
C1	325	175	∅ 12 POR TODO └─┘ ∅ 18 ▽ 12
C2	325	75	∅ 12 POR TODO └─┘ ∅ 18 ▽ 12
C3	225	175	∅ 12 POR TODO └─┘ ∅ 18 ▽ 12
C4	225	75	∅ 12 POR TODO └─┘ ∅ 18 ▽ 12





**D6.8 rosca a M8 amb mascle
D7.75 mandrinar a D8H7**

		Pol. Pla de la Font, parc 1 17832 - Crespià (Girona) www.technigas.com Telf. +34 972 57 09 88		MATERIAL:	ACER F114				
		EDIT -		DRAWN	A.Jovanet	DATE	-	RAW MATERIAL:	-
DESCRIPTION: Placa SUPERIOR matriu portamollos		CHECHED	X.Saus	DATE	-	TREATMENT:	-	SURF.TREATMENT	-
Nº 4.01				GENERAL TOLERANCES: ISO 2768-fH		WEIGHT: -		HARDNESS: -	
				DATA FILE: -		SCALE 1/5		FORMAT DIN A-4	
									
This drawing belongs to Technigas being prohibited its reproduction or gives to third without our authorization.									

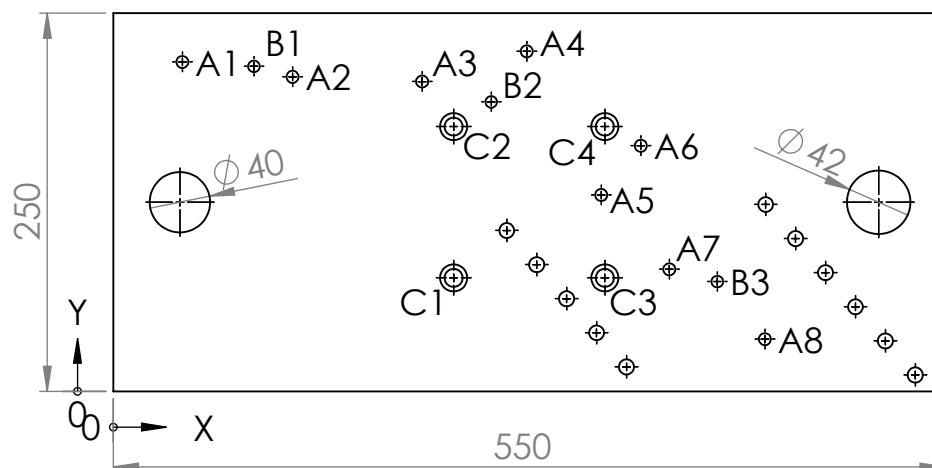
RÓTULO	UBIC X	UBIC Y	TAMAÑO
A1	45,63	217,76	Ø 6.8 POR TODO
A2	118,49	207,92	Ø 6.8 POR TODO
A3	204,18	204,80	Ø 6.8 POR TODO
A4	273,37	224,75	Ø 6.8 POR TODO
A5	322,58	129,79	Ø 6.8 POR TODO
A6	348,77	162,38	Ø 6.8 POR TODO
A7	367,62	80,68	Ø 6.8 POR TODO
A8	430,82	34,48	Ø 6.8 POR TODO
B1	92,98	214,86	Ø 7,75 POR TODO
B2	249,88	191,37	Ø 7,75 POR TODO
B3	399,33	72,53	Ø 7,75 POR TODO
C1	225	75	Ø 12 POR TODO └─┘ Ø 18 ▽ 12
C2	225	175	Ø 12 POR TODO └─┘ Ø 18 ▽ 12
C3	325	75	Ø 12 POR TODO └─┘ Ø 18 ▽ 12
C4	325	175	Ø 12 POR TODO └─┘ Ø 18 ▽ 12





**D6.8 roscar a M8 amb mascle
D7.75 mandrinar a D8H7**

		Pol. Pla de la Font, parc 1 17832 - Crespià (Girona) www.technigas.com Telf. +34 972 57 09 88		MATERIAL:	ACER F114
		EDIT		RAW MATERIAL:	-
DRAWN		NAME	A.Jovanet	DATE	-
CHECKED		NAME	X.Saus	DATE	-
DESCRIPTION: Placa INFERIOR matriu portamotllos (mec1)		SURF.TREATMENT		-	
Nº 4.02		GENERAL TOLERANCES:		ISO 2768-fH	
		DATA FILE:		-	
		SCALE	1/5	FORMAT	DIN A-4
					
This drawing belongs to Technigas being prohibited its reproduction or gives to third without our authorization.					

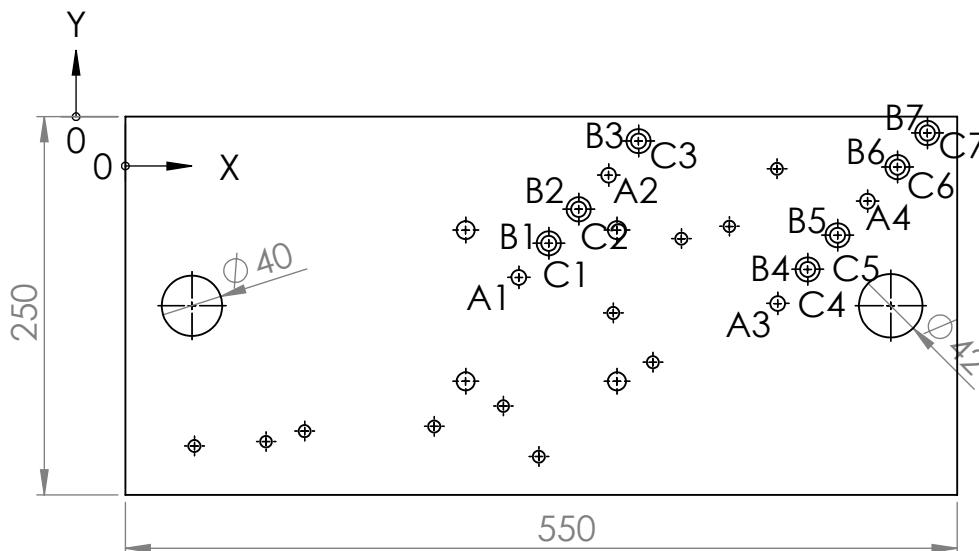
RÓTULO	UBIC X	UBIC Y	TAMAÑO
A1	260,14	-106,31	Ø 9,80 POR TODO
A2	319,51	-38,67	Ø 9,80 POR TODO
A3	431,32	-123,51	Ø 9,80 POR TODO
A4	490,69	-55,87	Ø 9,80 POR TODO
B1	279,93	-83,76	Ø 16 ∇ 10
B2	299,72	-61,22	Ø 16 ∇ 10
B3	339,30	-16,12	Ø 16 ∇ 10
B4	451,11	-100,96	Ø 16 ∇ 10
B5	470,90	-78,42	Ø 16 ∇ 10
B6	510,48	-33,32	Ø 16 ∇ 10
B7	530,27	-10,78	Ø 16 ∇ 10
C1	279,93	-83,76	Ø 10 POR TODO
C2	299,72	-61,22	Ø 10 POR TODO
C3	339,30	-16,12	Ø 10 POR TODO
C4	451,11	-100,96	Ø 10 POR TODO
C5	470,90	-78,42	Ø 10 POR TODO
C6	510,48	-33,32	Ø 10 POR TODO
C7	530,27	-10,78	Ø 10 POR TODO



D9.8 mandrinar a D10H7

		Pol. Pla de la Font, parc 1 17832 - Crespià (Girona) www.technigas.com Telf. +34 972 57 09 88		MATERIAL:	ACER F114
		EDIT		RAW MATERIAL:	-
DRAWN A.Jovanet		DATE	-	TREATMENT:	-
CHECKED X.Saus				SURF.TREATMENT	-
DESCRIPTION: Placa INFERIOR matriu portamollos (mec2)				HARDNESS:	-
				WEIGHT:	-
				GENERAL TOLERANCES:	ISO 2768-fH
				DATA FILE:	-
Nº 4.03		SCALE	1/5	FORMAT	DIN A-4
					
This drawing belongs to Technigas being prohibited its reproduction or gives to third without our authorization.					

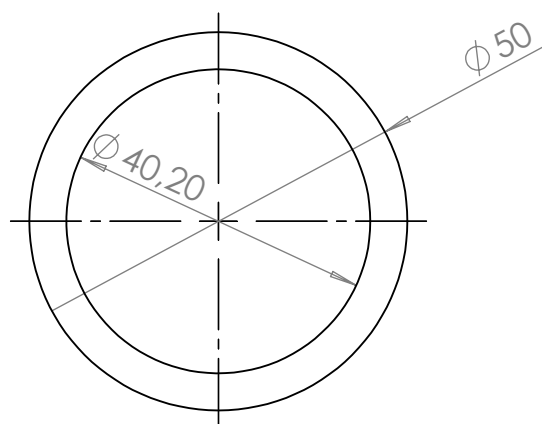
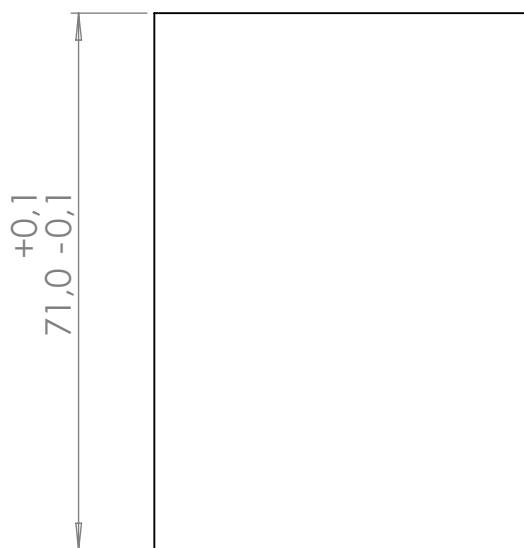
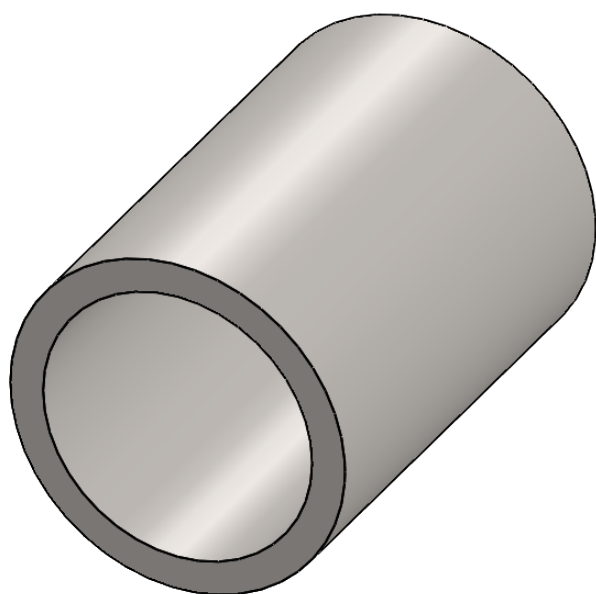

		Pol. Pla de la Font, parc 1 17832 - Crespià (Girona) www.technigas.com Telf. +34 972 57 09 88		MATERIAL:	ACER F111
				RAW MATERIAL:	Rodó calibrat D50
EDIT		NAME	DATE	TREATMENT:	-
	DRAWED	A.Jovanet	-	SURF.TREATMENT	-
	CHECHED	X.Saus	-	HARDNESS:	-
DESCRIPTION: Tope mecànic D40				WEIGHT:	-
				GENERAL TOLERANCES:	ISO 2768-fH
Nº 4.04				DATA FILE:	-
				SCALE 1/1	FORMAT DIN A-4
This drawing belongs Tecnigas being prohibited its reproduction or gives to third without our authorization.					